

▼ Shown from left to right: A-220, A-330 and A-310



## The Standard Workshop Tools



### Push Pin A-183

For applications requiring precision pressing, such as shaft removal and insertion. This attachment fits 10 ton cylinders and requires the use of a threaded adaptor saddle (A-13).

Page: 166



### Smooth Saddle A-185

For pressing applications of delicate parts, such as aluminium castings, this saddle decreases surface marks during the pressing application. Requires 10 ton cylinder and threaded adaptor saddle (A-13).

Page: 167



### 10 ton Bench Presses

For 10 ton VLP-Series Bench Presses selection see:

Page: 138

### C-Clamp Press

- 5, 10 and 20 ton capacity
- Operational in all positions.

### Arbor Press

- 10 and 30 ton capacity
- Foot mounting holes for horizontal or vertical positioning
- Machined working surfaces for easier fixturing
- Slotted back to simplify loading and unloading of longer parts.

▼ A-310 Arbor Press used for compacting powder at 10 ton.



### ▼ SELECTION CHART

Press Type	Press Capacity ton (kN)	Maximum Vertical Daylight (mm)	Maximum Bed Width (mm)	Press Model Number	Cylinder Model Number *	Page:
C-Clamp	5 (45)	165	51	A-205	5 ton RC-cylinder*	6
	10 (101)	228	57	A-210	10 ton RC-cylinder*	6
	20 (178)	305	70	A-220	25 ton RC-cylinder**	6
Arbor	10 (101)	227	135	A-310	10 ton RC-cylinder*	6
	30 (295)	260	178	A-330	RC-308*	6

\* Recommended cylinder must be ordered separately.

\*\* Must be limited to 20 ton.

# C-Clamp and Arbor Presses



▲ A perfect example of the force and versatility of the Enerpac A-220 C-Clamp press.

## A Series



Capacity:  
**5 - 30 ton**

Maximum Daylight x Width:  
**305 x 178 mm**

Maximum Operating Pressure:  
**700 bar**



### IMPORTANT!

For high-cycle production applications, the C-Clamp and Arbor presses should be limited to 50% of their capacity.

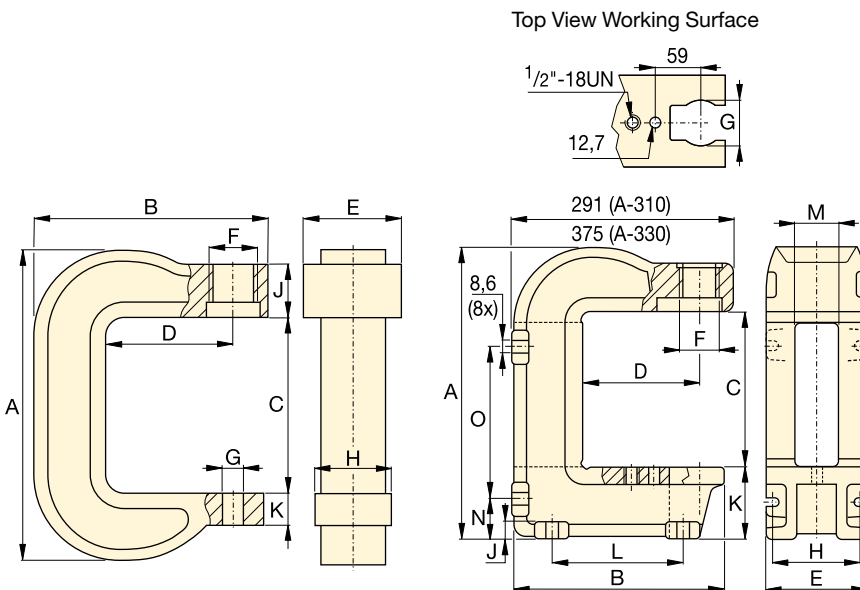

A-205, A-210, A-220

A-310, A-330



### Hydraulic Cylinders

Cylinders for C-Clamps and Arbor Presses must be ordered separately.

Page: 5



### Hydraulic Pumps

Pumps for C-Clamps and Arbor Presses must be ordered separately.

Page: 65

Press Dimensions (mm)															Press Model Number
A	B	C	D	E	F	G	H	J	K	L	M	N	O		
291	203	165	95	73	1½" -16 UN	26	51	66	25	-	-	-	-	7	A-205
406	283	228	152	83	2¼" -14 UN	26	76	64	41	-	-	-	-	17	A-210
540	346	305	152	108	3 <sup>5</sup> / <sub>16</sub> " -12 UN	26	95	70	44	-	-	-	-	38	A-220
414	281	227	152	135	2¼" -14 UN	63	122	19	97	175	65	54	219	27	A-310
557	353	260	152	178	3 <sup>5</sup> / <sub>16</sub> " -12 UN	63	140	25	165	203	67	98	276	86	A-330