

▼ PTA-1404



## Two-Stage Power in a Portable Design

- Compact and portable
- Handle located directly over pump's center of gravity for greater ease in carrying
- High bypass (125 bar) for faster torque cycles
- High power-to-weight ratio suits all Enerpac torque wrenches
- Glycerine filled pressure gauge with scales reading in bar/psi
- Transparent overlays in Nm and Ft.lbs for all Enerpac torque wrenches provide a quick torque reference
- Internal safety relief valve, factory preset.



### Torque Wrench Hoses

Use Enerpac twin safety hoses to connect your torque wrench to the pump.

For 700 bar	Model Nr.
6 m long, 2 hoses	THQ-706T
12 m long, 2 hoses	THQ-712T
For 800 bar	
6 m long, 2 hoses	THC-7062
12 m long, 2 hoses	THC-7122



### Gauge and Overlay Kit

Available separately for use with PTA-Series pumps:

**GT-4015Q** includes gauge and overlays for all

S- and W-Series wrenches.

**GT-4015** includes gauge and overlays for all SQD and HXD-Series wrenches.



◀ Easy and reliable service and maintenance with Enerpac steel wrenches powered by a pneumatic torque wrench pump.

# Compact Pneumatic Torque Wrench Pump

## PTA Series



Reservoir Capacity:

**3,8 litres**

Flow at Rated Pressure:

**0,33 l/min**

Air Consumption:

**1133 l/min**

Maximum Operating Pressure:

**700 - 800 bar**

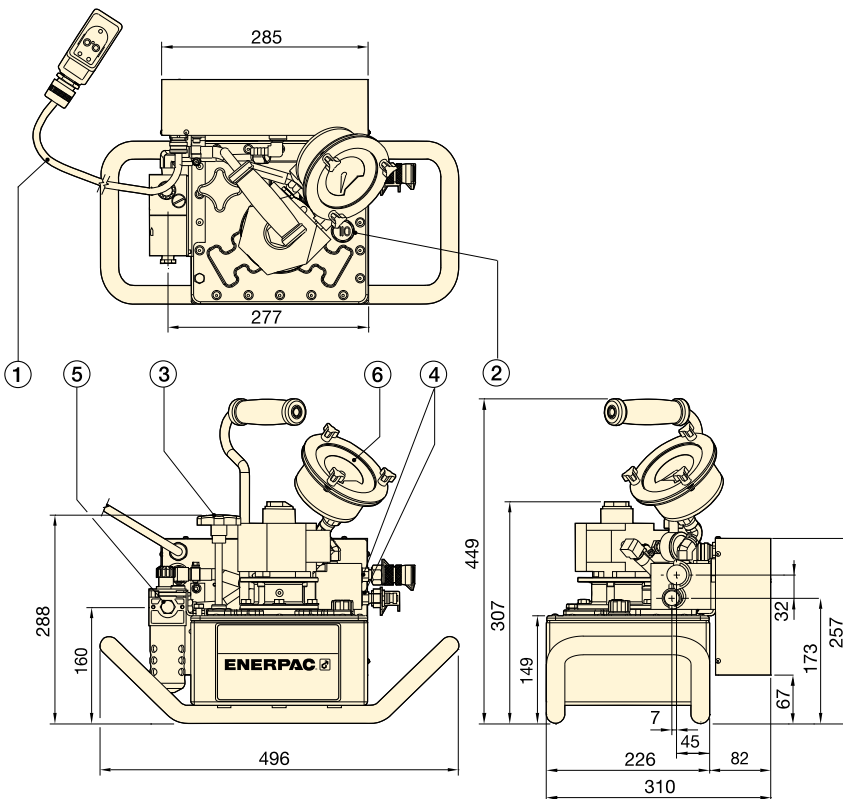

- ① 5 mtr Air control pendant
- ② Vent/Fill plug
- ③ Externally adjustable relief valve
- ④ 1/4"-18 NPTF Hydraulic ports
- ⑤ 3/8"-18 NPTF Air inlet
- ⑥ Gauge with overlay kit



### Torque Wrench Pump Selection Matrix

For optimum speed and performance see the torque wrench pump and hose selection matrix.

Page: 32

### OIL FLOW VERSUS PRESSURE

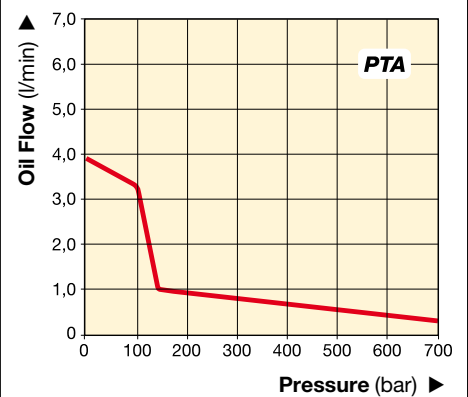

### ▼ PERFORMANCE CHART

For Use With Torque Wrenches		Pressure Rating (bar)		Model Number	Oil Flow Rate (l/min)		Reservoir Capacity (litres)	Useable Oil (litres)	Air Consumption at 7 bar (l/min)	Air Pressure Range (bar)	Weight (kg)
		1st stage	2nd stage		1st stage	2nd stage					
S1500 S3000	W2000 W4000	125	700	PTA-1404-Q	3,9	0,33	3,8	1,9	1133	3,4 - 7,0	24,5
SQD-25-I SQD-50-I	HXD-30 HXD-60	125	800	PTA-1404	3,9	0,33	3,8	1,9	1133	3,4 - 7,0	24,5