

Sizes 45, 80, 112, 140  
and 200  
Up to 203 kW  
and 320bar

Swash-plate  
Axial Piston Pump  
B Series K3VL

Data Sheet  
P-1002/01.06  
GB

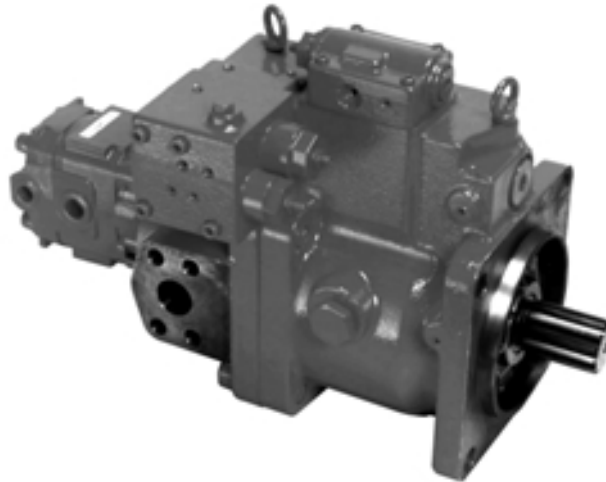

#### Features

- ◇ SAE and ISO mount.
- ◇ Small installation envelope.
- ◇ Through drive.
- ◇ SAE and metric ports.
- ◇ Side and rear porting.
- ◇ Vertical mount capability.
- ◇ Multiple drain ports.
- ◇ CW and CCW rotation.
- ◇ Opposed stroking pistons.
- ◇ Rated pressure 320 bar.
- ◇ Swash plate pillow support.
- ◇ Maximum displacement stop.
- ◇ Servo assist springs.
- ◇ Hydrostatic pillow bearing.
- ◇ Overcentre bleed.
- ◇ Pressure compensation.
- ◇ Integral proportional pressure.
- ◇ Load sensing.
- ◇ Integral unload.
- ◇ Torque limiter.
- ◇ Rigid construction.
- ◇ Long life roller bearings.
- ◇ Various sealing options.
- ◇ Low pulsation.
- ◇ Proven rotating group.
- ◇ Sine wave valve plate.
- ◇ Separate swash plate.
- ◇ Spherical valve plate.
- ◇ Super-finished bores.
- ◇ Solid pistons.

Model  
K3VL

Page  
1.64

Data Sheet  
P-1002/01.06

**Kawasaki**  
Hydraulic Products

**General Description**

The K3VL Series Swash Plate Type Axial Piston Pumps are designed to specifically satisfy the mobile, marine and general industrial machinery market where a medium pressure variable displacement pump is required. K3VL Pumps are available in nominal displacements ranging from 45 to 200 cm<sup>3</sup>/rev with various pressure, torque limiter, and combination load sensing control options.

**Technical Description**

The components of the K3VL pump can be divided into three sub-groupings:

- Rotating Group** – Providing the main rotary pumping action.
- Swash Plate Group** – To vary the pump's delivery flow rate.
- Valving Cover Group** – Providing the switching of oil between suction and delivery ports.

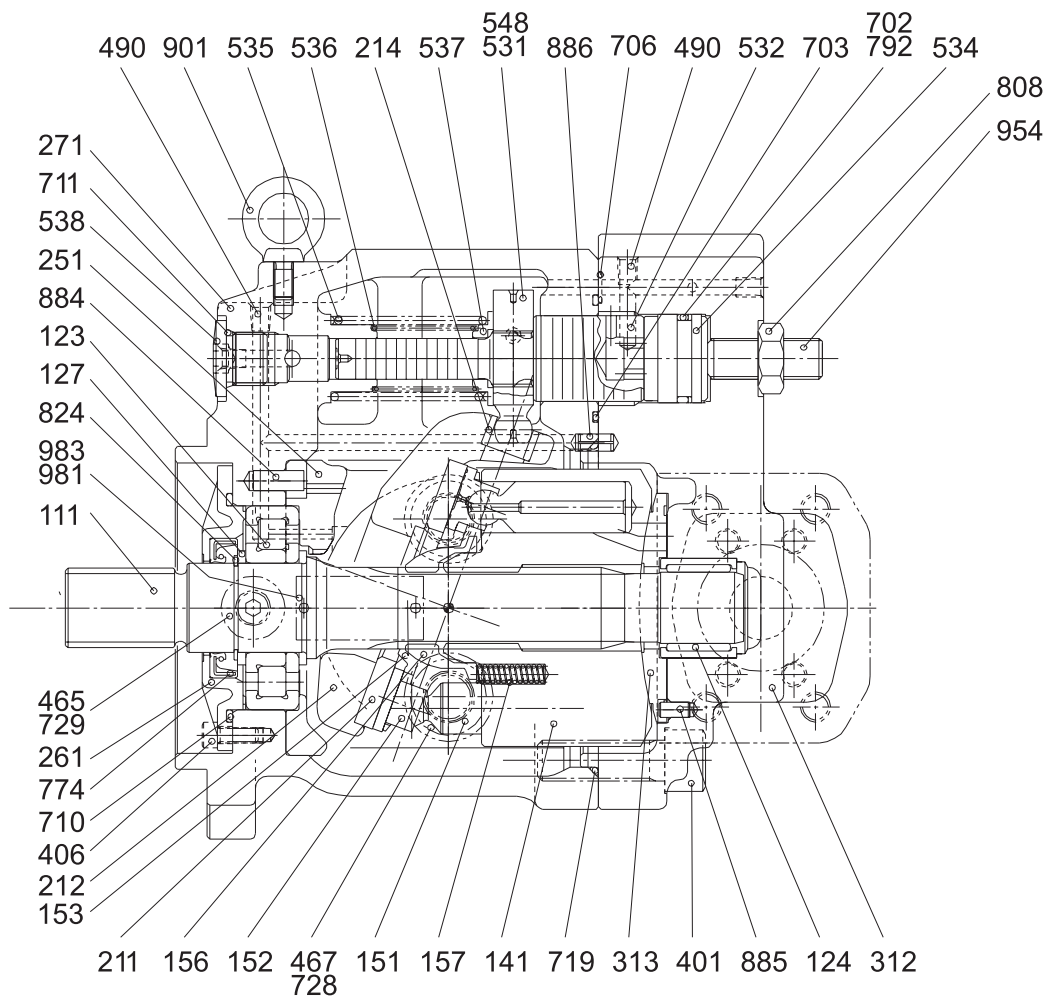

**K3VL80 Cross Section**



**Technical Description (continued)****The Rotating Group**

The Rotating Group comprises:

- (a) Drive shaft, 111
- (b) Cylinder block, 141
- (c) Pistons, 9 x 151
- (d) Shoes, 9 x 152
- (e) Setting plate, 153
- (f) Spherical bush, 156
- (g) Cylinder springs, 9 x 157

The drive shaft is coupled to the cylinder block through a splined section and supported at both of its ends by bearings and the drive shaft. The shoe is swaged over the spherical end of the piston forming a spherical ball joint. Additionally the shoe has a hydrostatic pocket to balance the hydraulic thrust developed by the piston pressure allowing the shoe to lightly slide against the shoe plate.

The subgroup consisting of the pistons and shoes are pressed against the shoe plate by the cylinder springs acting through the setting plate and the spherical bush. The force developed by these cylinder springs also press the cylinder block against the valve plate. With the smallest K3VL45 unit a single centralised spring with individual push pins provide the shoe and cylinder block hold down force.

**Swash Plate Group**

The Swash Plate Group comprises:

- (a) Swash plate, 212
- (b) Shoe plate, 211
- (c) Swash plate support, 251
- (d) Tilting bush, 214
- (e) Tilting pin, 531
- (f) Servo piston, 532
- (g) Servo assist springs, 535 & 536

The swash plate on the reverse side to the shoe location is a cylindrical form which is a "pillow" supported by the hydrostatic bearing provided by the swash plate support. The tilting bush is inserted into the swash plate and into this is installed the spherical portion of the tilting pin which is coupled to the servo piston.

Any linear movement of the servo piston produced by the regulator pressure applied to either end is translated through the tilting pin into an angular movement of the swash plate which varies the tilting or swash angle of the pump. A screw adjuster and lock nut is available to adjust the maximum tilting angle condition. The servo assist springs are provided to ensure good on stroking response particularly at low operating pressures.



**Technical Description (continued)****Valve Cover Group**

The Valve Cover Group comprises:

- (a) Valve cover, 312
- (b) Valve plate, 313
- (c) Valve plate, 885

The valve plate with its two "kidney" shaped ports is installed onto the valve plate located by the valve plate pin. These two ports serve to supply and exhaust oil to and from the cylinder block. The oil passage switched by the valve plate is connected to the externally piped suction and outlet pressure ports through the valve cover. This valve plate is spherical in form for all but the smallest 45 unit.

**Pump Operation**

When the pump's drive shaft is driven by a prime mover (Electric motor, Engine etc.), the cylinder block being spline coupled to the shaft will also rotate. If the swash plate has been tilted, the pistons arranged in the cylinder block due to the shoe being retained on the swash plate surface will both rotate with the cylinder block and reciprocate once per revolution. Paying attention to one such piston then it will move away from the valve plate for half a rotation (suction stroke) and move towards the valve plate for the second half of rotation (oil delivery stroke). The larger the tilt angle, the longer the piston stroke and the higher is the pump's displacement. As the swash plate tilting angle approaches so the piston makes no stroke and thereby delivers no oil.

**Through Drive Option**

The pump is available with a through drive capability (see installation section) where a through drive shaft with splined end is incorporated capable of taking a similar torque to that of the pump itself and an SAE "A" mounting interface is provided.

By suitable use of adaptors and splined couplings a wide variety of through drive mounting capabilities are available. The formation of these kits and their relevant part numbers will be found in the installation section.



Model  
K3VL

Page  
4.64

Data Sheet  
P-1002/01.06

**Technical Data**

For applications outside the following parameters, please consult Kawasaki Precision Machinery (UK) Ltd.

**Hydraulic Data**

Pressure Fluid

Mineral oil, phosphate ester, fatty acid ester and water glycol.  
Phosphate ester is only suitable for use with FPM seals.

Use a high quality, anti-wear, mineral based hydraulic fluid when the pressure exceeds 207 bar. In applications where fire resistant fluids are required consult Kawasaki Precision Machinery (UK) Ltd. The following chart illustrates the effects on pump life when non-standard fluids are used:

**Fluid selection**

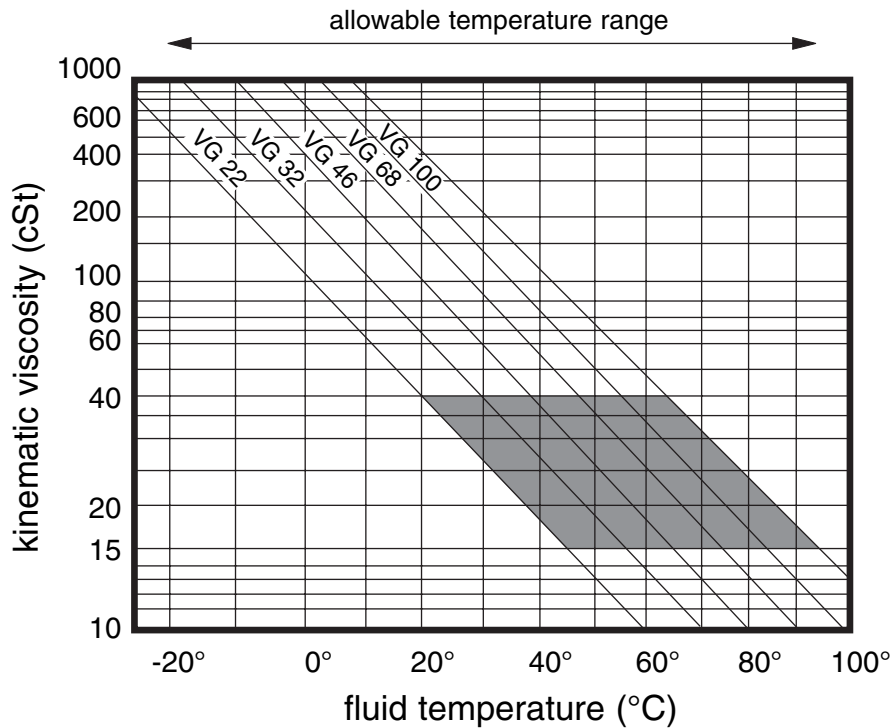

**Technical Data (continued)****Filtration & Contamination Control****Filtration**

The most important means to prevent premature damage to the pump and associated equipment and to extend its working life, is to ensure that hydraulic fluid contamination control of the system is working effectively.

This begins by ensuring that at the time of installation that all piping, tanks etc. are rigorously cleaned in a sanitary way. Flushing should be provided using an off line filtration system and after flushing the filter elements should be replaced.

A full flow return line filter of 10 micron nominal should be utilised and in addition a 150 micron mesh suction strainer is recommended. Typical filtration circuits are shown in the K3VL brochure.

To prevent contaminant ingress from the external environment a 5 to 10 micron filter within the tanks breather is also recommended.

**Suggested Acceptable Contamination Level**

The relationship between contamination level and pump life is very difficult to predict as it depends on the type and nature of the contaminant present in the system. Sand or Silica in particular, due to its abrasive nature, does significantly reduce the expected life of a pump.

Based on the precondition that there is no significant presence of Silica type substances then a minimum Cleanliness level of 18/15 to ISO/DIS 4406 (NAS Class 9) is recommended.

**Working Fluid Types****Anti-Wear Type Hydraulic fluid**

It is generally recommended to use an anti-wear type hydraulic fluid as the mineral oil type when the operating pressure exceeds 210 bar.

**Fire-resistant Fluids**

Some kind of fire-resistant fluids require special materials for seals, paint and metal finishing. Please consult Kawasaki Precision Machinery (UK) Limited and provide details of the particular fluid specification and the working conditions so that any special requirements can be ascertained.

In general, fire-resistant fluids have a low viscosity index and their viscosity also changes significantly with operating temperature and service life. For this reason, the circuit should be provided with an adequately sized cooler or forced cooling so that temperatures can be stabilised.

Due to the inherent water content of some of these fluids the minimum allowable suction pressure will be higher than that of an equivalent mineral oil and so needs to be fully evaluated by Kawasaki Precision Machinery (UK) Limited. The following table provides an overview of the precautions and characteristics that can be expected with these types of fluids.

Model  
K3VL

Page  
6.64

Data Sheet  
P-1002/01.06



**Kawasaki**  
Hydraulic Products

**Technical Data (continued)**

## Fire-resistant Fluids (continued)

parameter :- / fluid type:-	mineral oil	phosphate ester	polyol ester	water glycol
Maximum Pressure (bar)	320	320	320	210
Recommended Temperature Range (deg C)	20 ~ 60	20 ~ 60	20 ~ 60	10 ~ 50
Cavitation susceptibility	○	△	△	△
Expected life expectancy compared to mineral oil	100%	60% ~ 100%	50% ~ 100%	20% ~ 80%

○ recommended

△ usable (higher density)

**Technical Data (continued)****Pump Start Up Precautions****Pump Case Filling**

Be sure to fill the pump casing with oil through the drain port - filling only the suction line with oil is totally insufficient. The pump contains bearings and high-speed sliding parts including pistons with shoes and spherical bushes that need to be continuously lubricated. Part seizure or total premature failure will occur very quickly if this procedure is not rigidly followed.

**Piping & Circuit Checking**

Check to see that the piping and full hydraulic circuit is completed and that any gate valves etc. are open.

**Direction of Rotation Check**

Check to ensure that direction of rotation is correct and that the suction and delivery lines are connected correctly.

**Start Up**

Jog start the motor and check once more for correct rotation. Run the pump unloaded for a period to ensure that all residual air within the system is released. Check for external leakage, abnormal noise and vibrations

**Case Drain Pressure**

Please ensure, as stated previously, that the maximum steady state drain line pressure at the pump casing does not exceed 1 bar. (Maximum peak pressure 4 bar). A suitable drain line hose and drain line filter when required must be selected to ensure this.

**Long Term Out of Usage**

It is undesirable to leave the pump out of use for a long period of a year or more. In such a situation it is recommended that the pump is run for a short period on a more frequent basis even if it is just unloaded. With regard to a pump held in storage then rotating the shaft on a frequent basis is sufficient. If the pump is left out for more than the suggested time it will require a service inspection.



Model  
K3VL

Page  
8.64

Data Sheet  
P-1002/01.06



**Technical Data (continued)**

Specifications

The following table shows the specifications for the complete K3VL pump range.

More detailed efficiency curves and other related information will be found in a later section.

pump model		45	80	112	140	200				
capacity		cc/rev	45	80	112	200				
pressure ratings	rated	bar	320							
	peak	bar	350							
Speed ratings	self prime	rpm	2700	2400	2200	1900				
	max. boosted	rpm	3250	3000	2700	2200				
min operating speed		rpm	600							
case drain	max	bar	1							
pressures	peak	bar	4							
Weight		kg	25	34	60	100				
case fill capacity		cc	600	800	1000	1000				
max allowable input torque		Nm	225	400	981	1000				
mounting flange	type	SAE B	ISO 100	SAE C	ISO 125	SAE D	ISO 180	SAE D	ISO 180	SAE E
	bolts	2	2	2	2	4	4	4	4	4
input shaft	type	SAE B-B	ISO 25mm	SAE C	ISO 32mm	SAE D	ISO 45mm	SAE D	ISO 45mm	SAE D
	form	spline & key	key	spline & key	key	spline & key	key	spline & key	key	spline & key
allowable through drive torque	SAE 'A'	Nm	61							
	SAE 'A-A'		118							
	SAE 'B'		203							
	SAE 'B-B'		225							
	SAE 'C'						400			
	SAE 'C-C'						559			
	SAE 'D'						699			
Temperature range		°C	-20 to 95							
viscosity range		cSt	10 to 1,000							
max. contamination level			18/15 (ISO/DIS 4406)							

Notes:

**Rated Pressure**

Pressure at which life and durability will not be affected.

**Peak Pressure**

The instant allowable surge pressure as defined by DIN 24312. Life and durability however will be shortened.

**Maximum Self Priming Speed**

Values are valid for an absolute suction pressure of 1 bar. If the flow is reduced, or if the inlet pressure is increased the speed may also be increased (refer to section 4.2)

**Maximum Boosted Speed**

Values stated are the absolute maximum permitted speed for which an increased inlet pressure will be required. (refer to section 4.2)

**Weight**

Approximate dry weights, dependant on exact pump type.

**Hydraulic Fluid**

Mineral anti wear hydraulic fluid – for other fluid types please consult KPM

**Viscosity Range**

If viscosity is in range 200 to 1,000 cSt, then warming up is necessary before commencing full scale running.



<b>Ordering Code – K3VL Series</b>			
<b>K3VL</b>	<b>80</b>	<b>B</b>	<b>- 1 0 R S S</b>
<b>L</b>	<b>O</b>	<b>12D</b>	<b>/1 H*</b>
<p><b>K3VL Series Pump</b></p>			<p><b>Additional control options</b> Blank Without additional limiter</p> <p><b>Torque limit control</b> /1-L* Low setting range /1-M* Medium setting range /1-H* High setting range</p> <p><b>Displacement control (Without torque limit)</b> /1-E0 Electrical displacement control (pilot pressure required) /1-Q0 Pilot operated displacement control</p> <p><b>Parallel control control (Without torque limit)</b> /1-PP Parallel pressure compensation control</p>
<p><b>Maximum displacement</b> 45 45 cm<sup>3</sup>/rev 80 80 cm<sup>3</sup>/rev 112 112 cm<sup>3</sup>/rev 140 140 cm<sup>3</sup>/rev 200 200 cm<sup>3</sup>/rev</p>			
<p><b>Design series</b> B</p>			
<p><b>Hydraulic Fluid Type</b> – Mineral oil W Water glycol Z Phosphate ester</p>			
<p><b>Circuit type</b> 1 Open circuit</p>			
<p><b>Through drive &amp; porting</b> 0 Single pump, side ported A SAE "A" through drive, side ported B SAE "B" through drive, side ported BB SAE "BB" through drive, side ported C SAE "C" through drive, side ported D SAE "D" through drive, side ported R Single pump, rear ported S Single pump with plastic cover (Stock Pump) N Single pump with Steel cover, side ported</p>			<p><b>Unloader solenoid (Type N below)</b> blank For all other options except PN &amp; LN 115A 115V AC, 50.60Hz, DIN 43550 Plug 235A 230V AC, 50.60Hz, DIN 43550 Plug 12D 12V DC, DIN 43550 Plug 24D 24V DC, DIN 43550 Plug</p>
<p><b>Direction of rotation</b> R Clockwise rotation L Counter-clockwise rotation</p>			<p><b>Additional pressure control</b> 0 No additional control N With integrated unloading valve V With integrated remote control valve R With inverse integrated remote control valve 1 Load sensing only (R4 plugged)</p>
<p><b>Mounting flange &amp; shaft</b> S SAE spline &amp; mount (see drawing for detail) M ISO key &amp; mount (see drawing for detail) (not 200) K SAE key &amp; mount (see drawing for detail) T* SAE B spline &amp; SAE B 2 bolt mount for 45 (not 80) SAE CC spline &amp; SAE D 4 bolt mount for 112/140 (not 200) U* 45 only, SAE B key &amp; SAE B 2 bolt mount C* 112/140 only, SAE C spline &amp; SAE C 2 bolt mount R* 112/140 only, SAE C spline &amp; SAE D 4 bolt mount X* 112/140 only, SAE C key &amp; SAE C 2 bolt mount W* 112/140 only, SAE CC spline &amp; SAE C 2 bolt mount (*Non standard options)</p>			<p><b>Control device configuration</b> P Remote pressure compensator L Load sensing &amp; pressure control</p>
			<p><b>Porting threads</b> M Metric threaded S UNC threaded</p>
Model K3VL	Page 10.64	Data Sheet P-1002/01.06	

**Performance - K3VL45**

**Performance Curve**

(Speed Range 1500 rpm & 1800 rpm with atmospheric inlet)  
 Test temperature 50°C, Viscosity 31cSt (ISO VG 46)

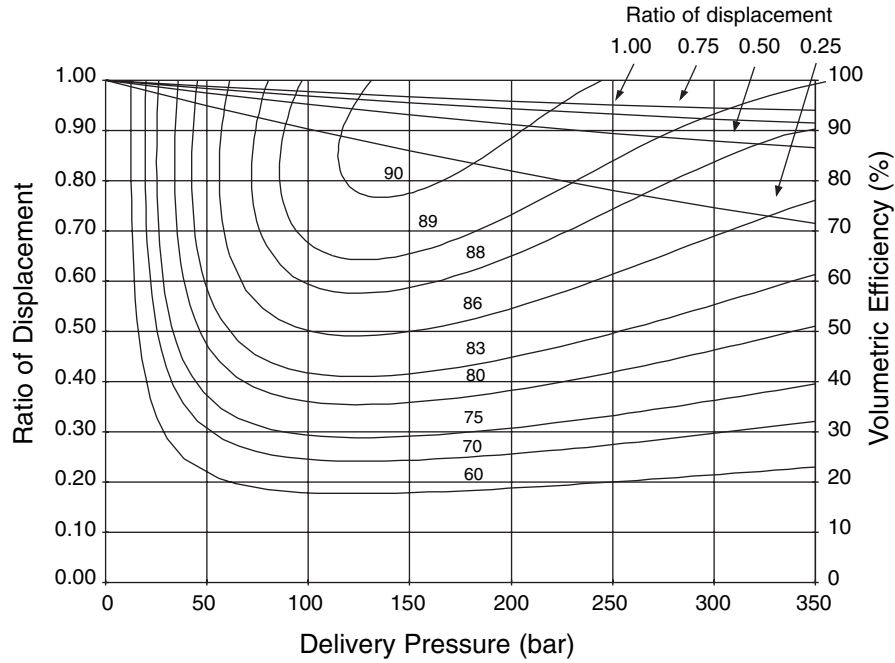

**Power Curve**

Note: Atmospheric Inlet, Full displacement

**K3VL45 Theoretical Power Curve**

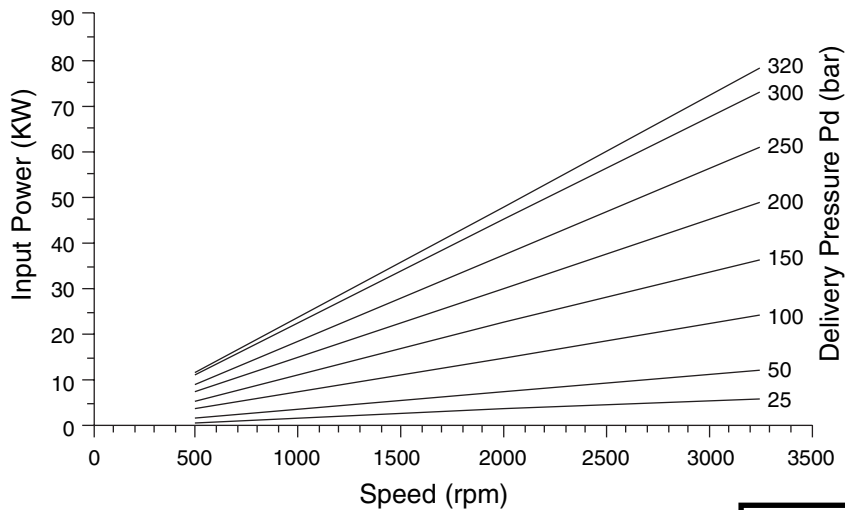

**Performance K3VL80**

**Performance Curve**

(Speed Range 1500 rpm & 1800 rpm with atmospheric inlet)  
 Test temperature 50°C, Viscosity 31cSt (ISO VG 46)

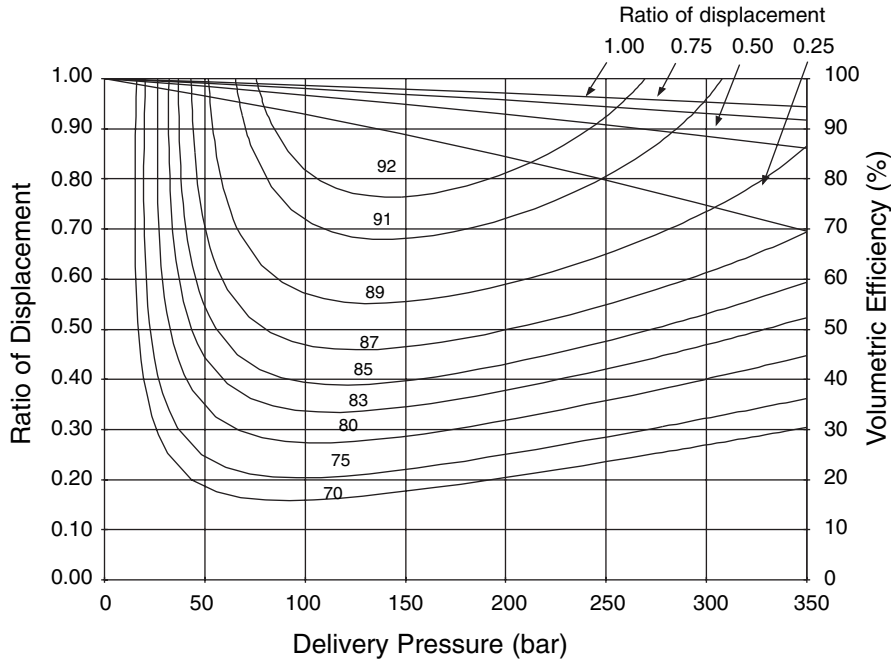

**Power Curve**

Note: Atmospheric Inlet, Full displacement

**K3VL80 Theoretical Power Curve**

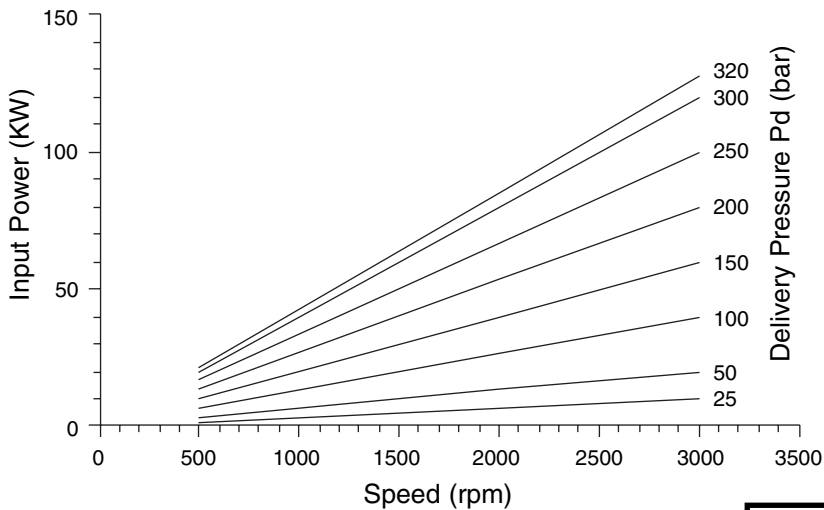

**Performance - K3VL112**

**Performance Curve**

(Speed Range 1500 rpm & 1800 rpm with atmospheric inlet)  
 Test temperature 50°C, Viscosity 31cSt (ISO VG 46)

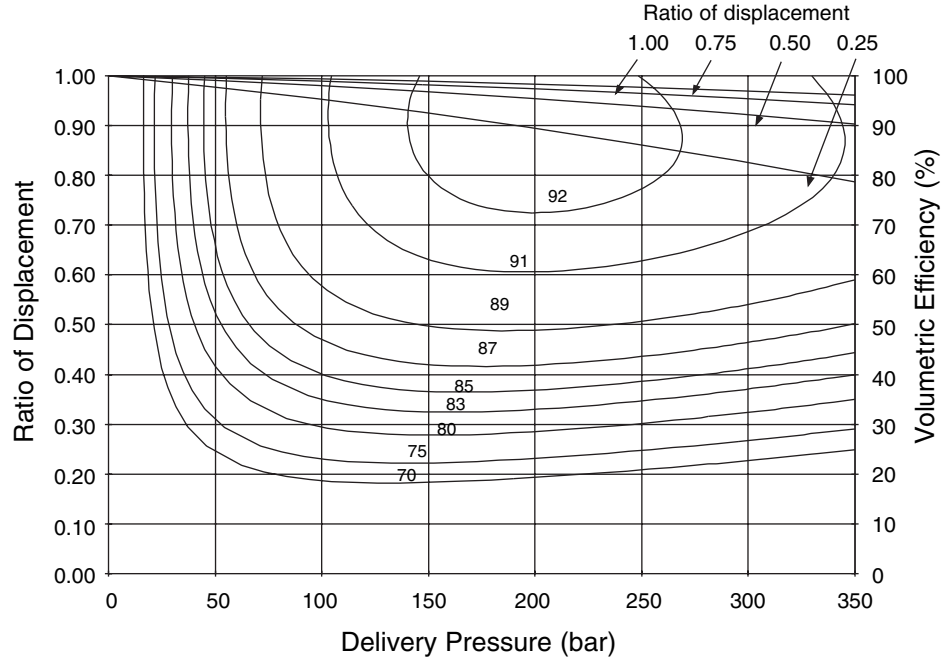

**Power Curve**

Note: Atmospheric Inlet, Full displacement

**K3VL112 Theoretical Power Curve**

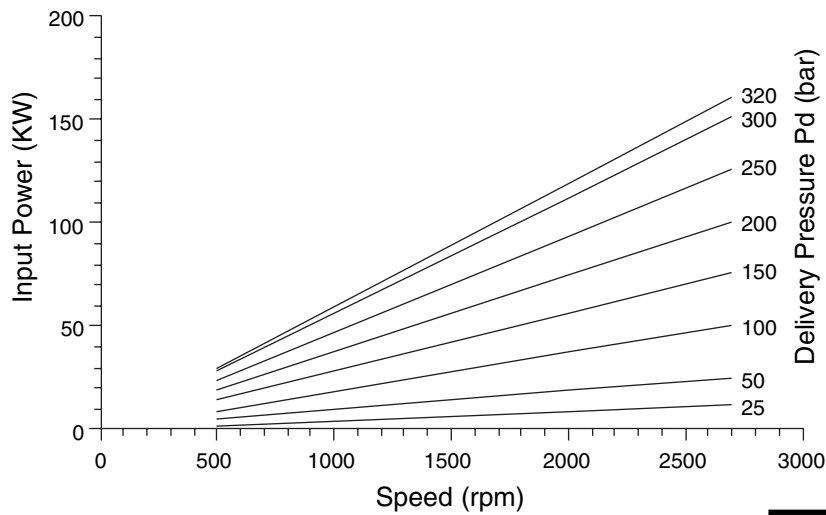

**Performance - K3VL140**

**Performance Curve**

(Speed Range 1500 rpm & 1800 rpm with atmospheric inlet)  
 Test temperature 50°C, Viscosity 31cSt (ISO VG 46)

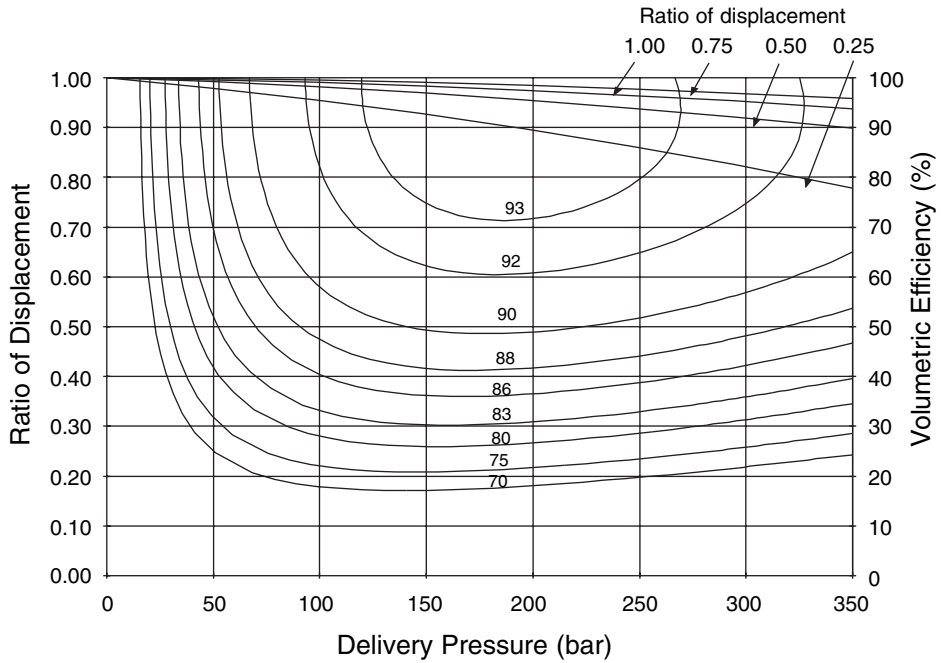

**Power Curve**

Note: Atmospheric Inlet, Full displacement

**K3VL140 Theoretical Power Curve**

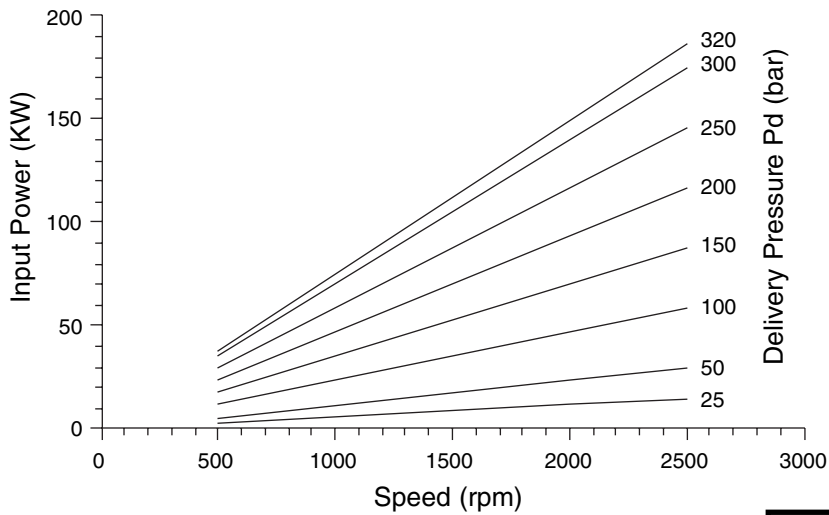

**Performance - K3VL200**

**Performance Curve**

(Speed Range 1500 rpm & 1800 rpm with atmospheric inlet)  
 Test temperature 50°C, Viscosity 31cSt (ISO VG 46)

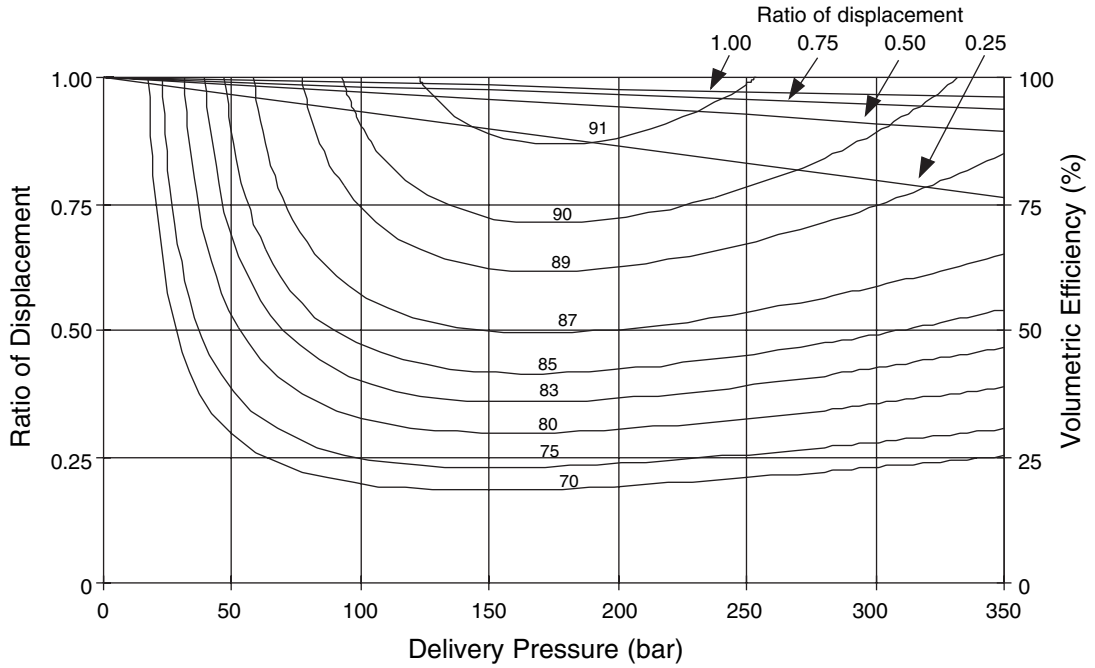

**Power Curve**

Note: Atmospheric Inlet, Full displacement

**K3VL200 Theoretical Power Curve**

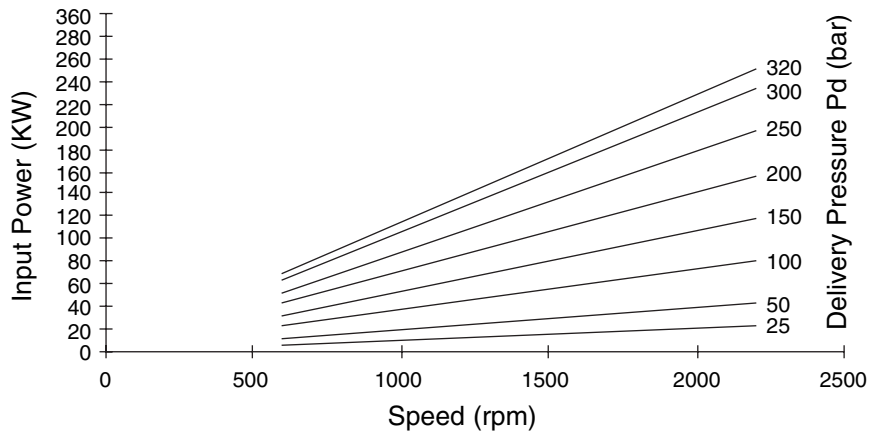

**Self Priming Curves**

**K3VL45 Self Priming Capability**

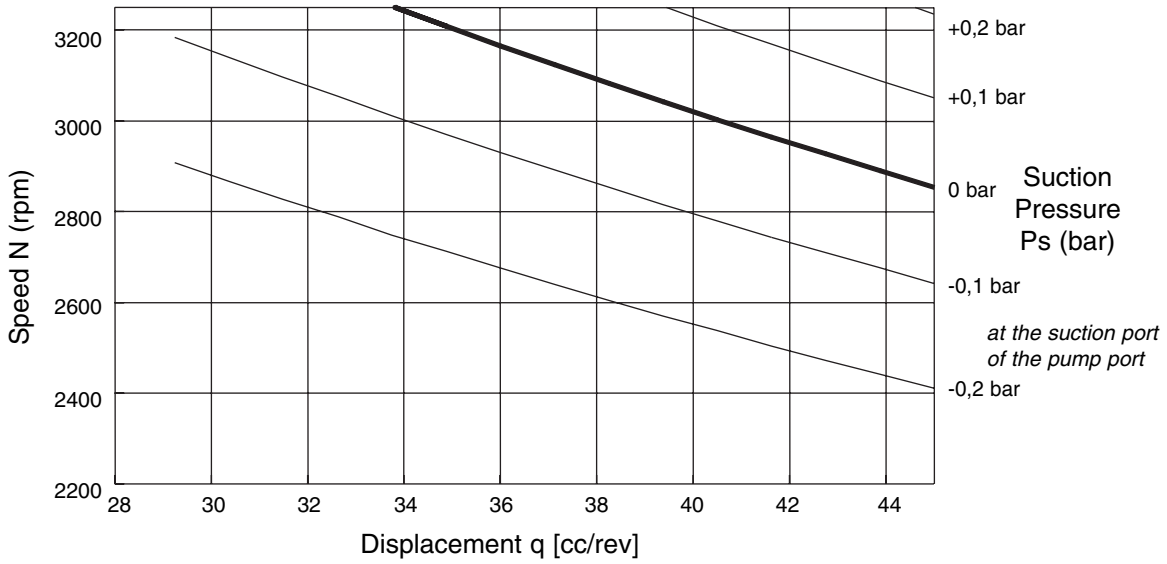

**K3VL80 Self Priming Capability**

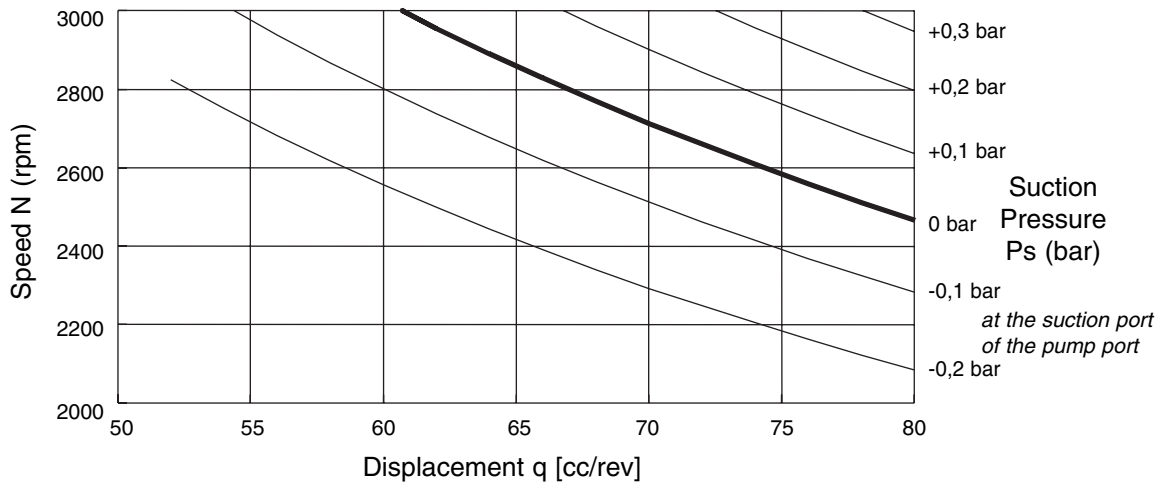



**Self Priming Curves (continued)**

**K3VL112 Self Priming Capability**

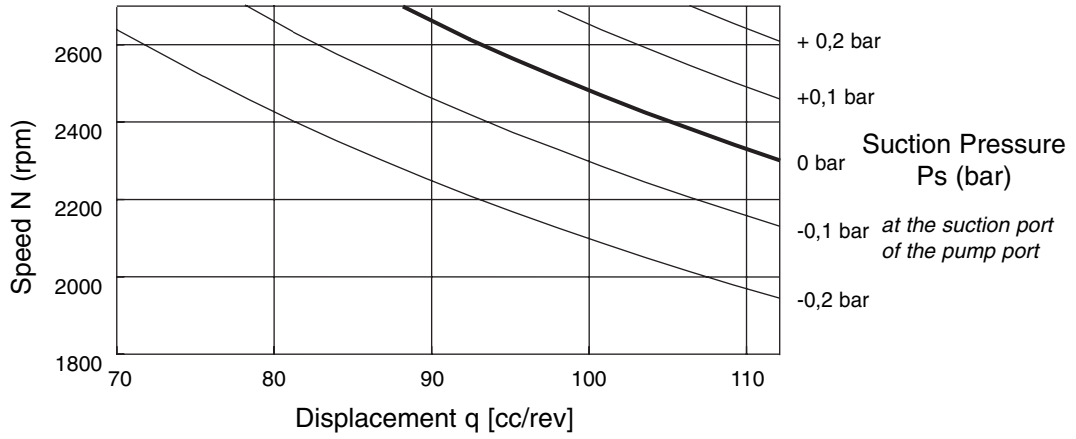

**K3VL140 Self Priming Capability**

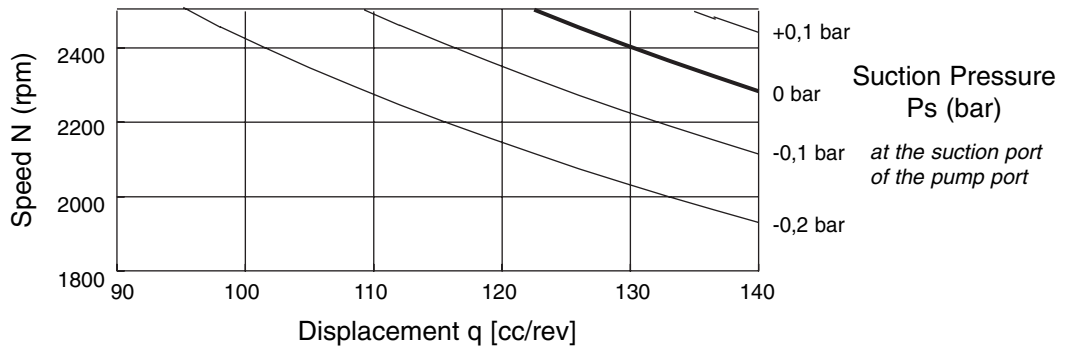

**Self Priming Curves**

**K3VL200 Self Priming Capability**

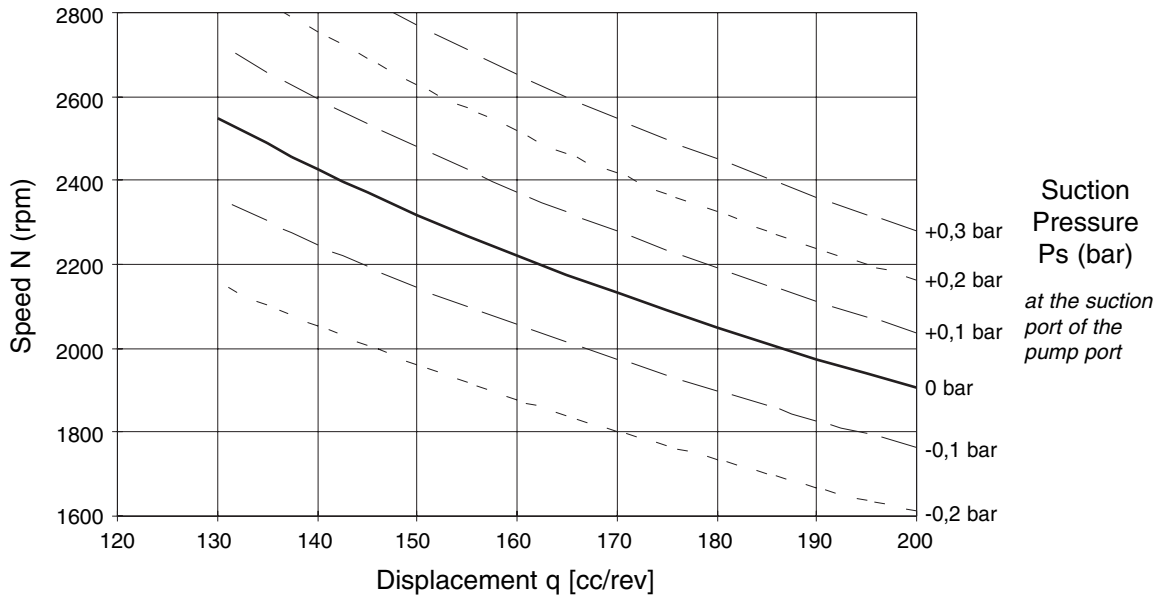

**Pressure pulsation**

**K3VL45 pulsation graph**

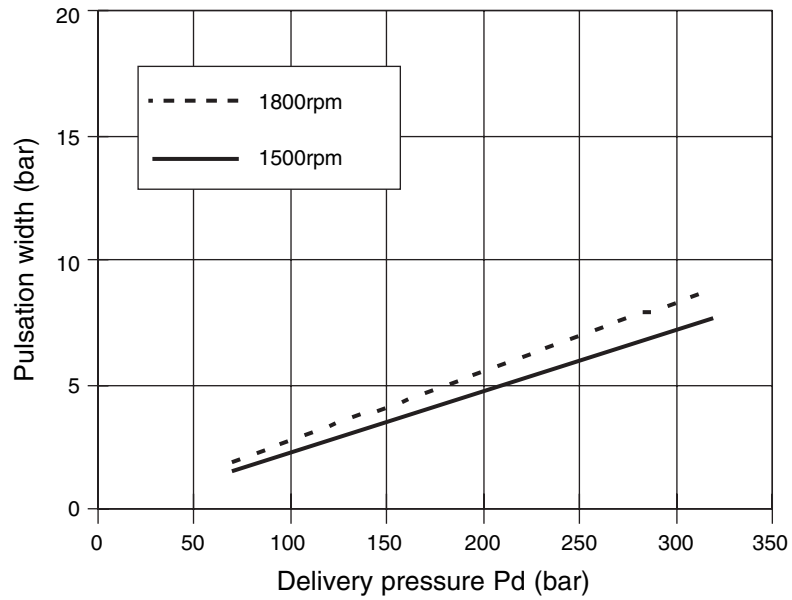

**K3VL80 pulsation graph**

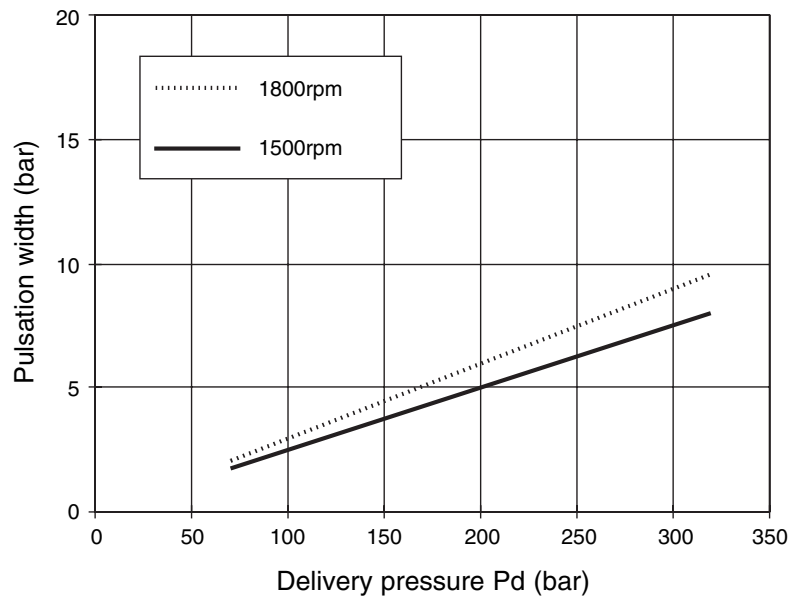

**Pressure pulsation (continued)**

**K3VL112 pulsation graph**

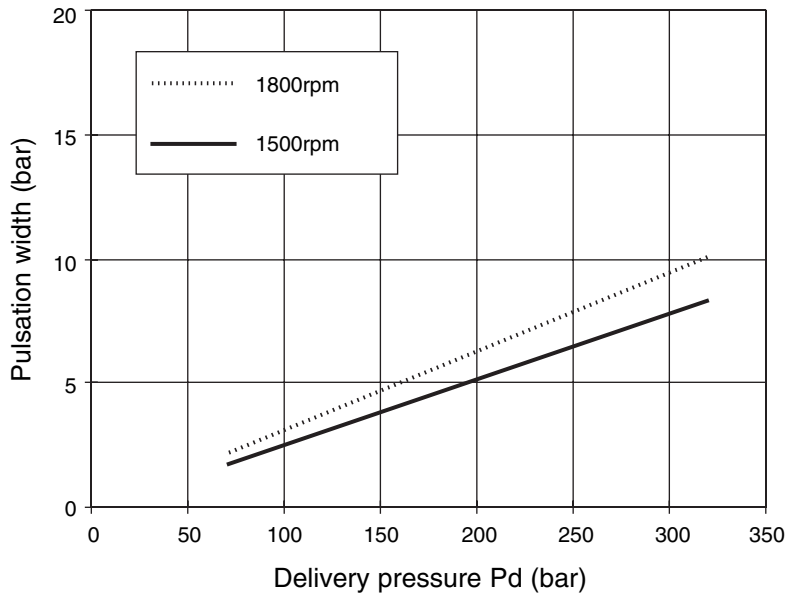

**K3VL140 pulsation graph**

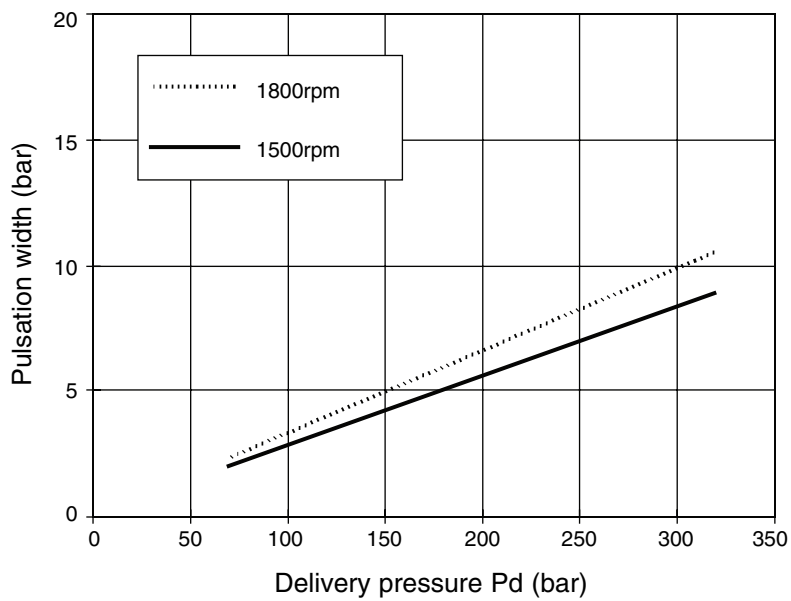

**Pressure pulsation (continued)**

**K3VL200 pulsation graph**

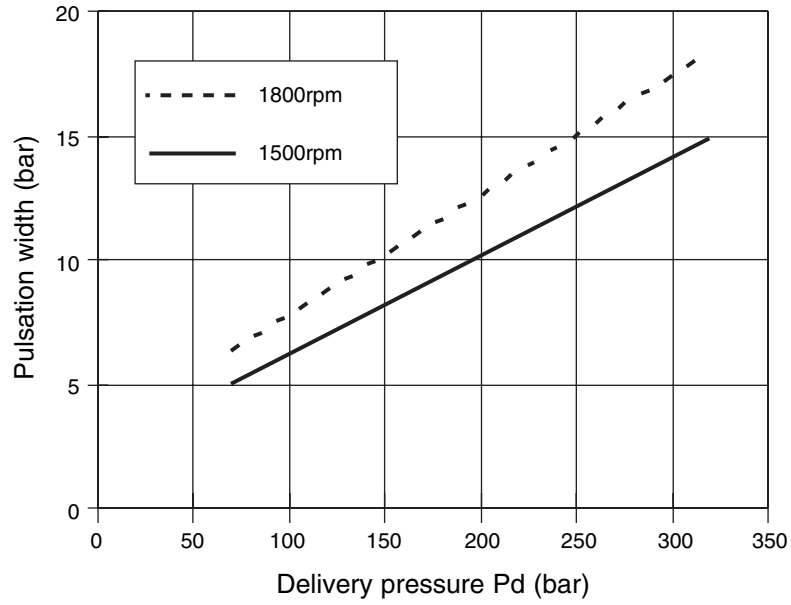

**Bearing Life (Full Displacement)**

**K3VL45**

Note: Service and other life factors have unity value

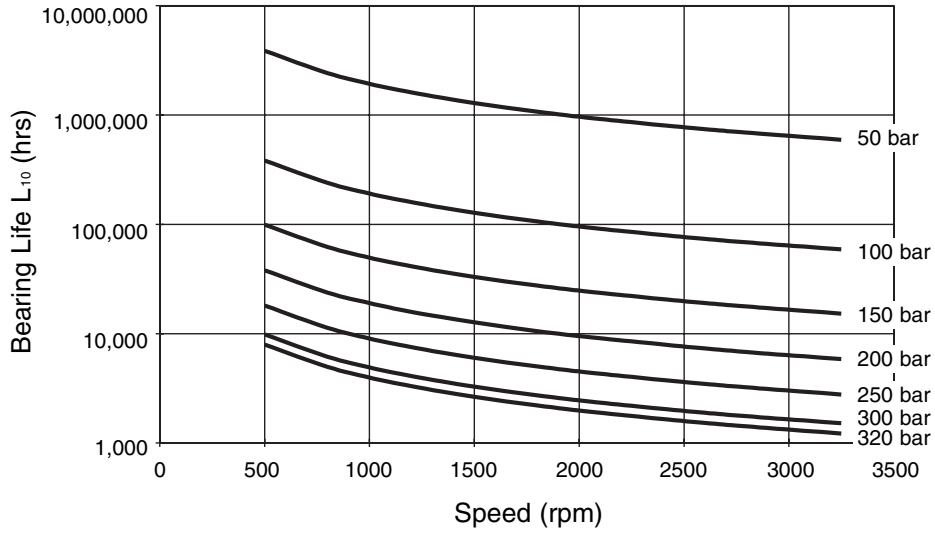

**K3VL80**

Note: Service and other life factors have unity value

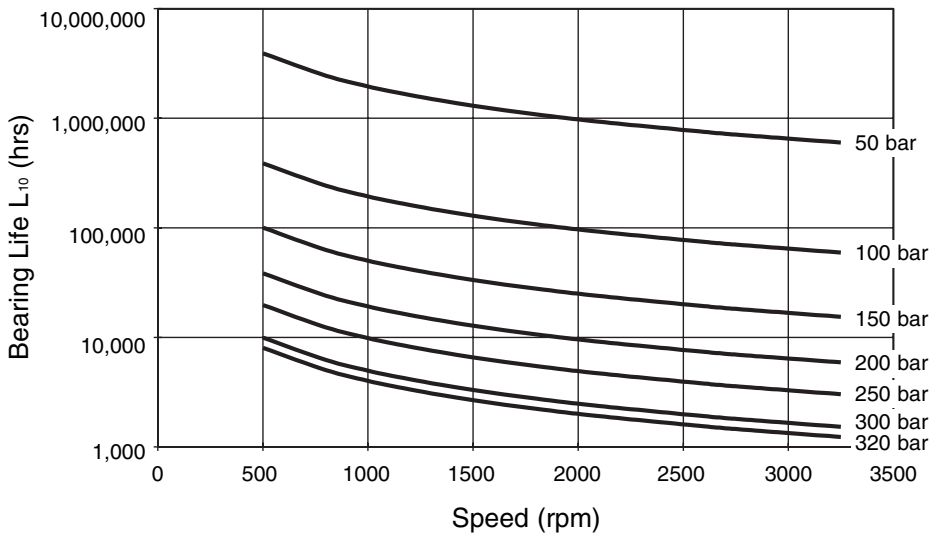

**Bearing Life (Full Displacement) (continued)**

**K3VL112**

Note: Service and other life factors have unity value

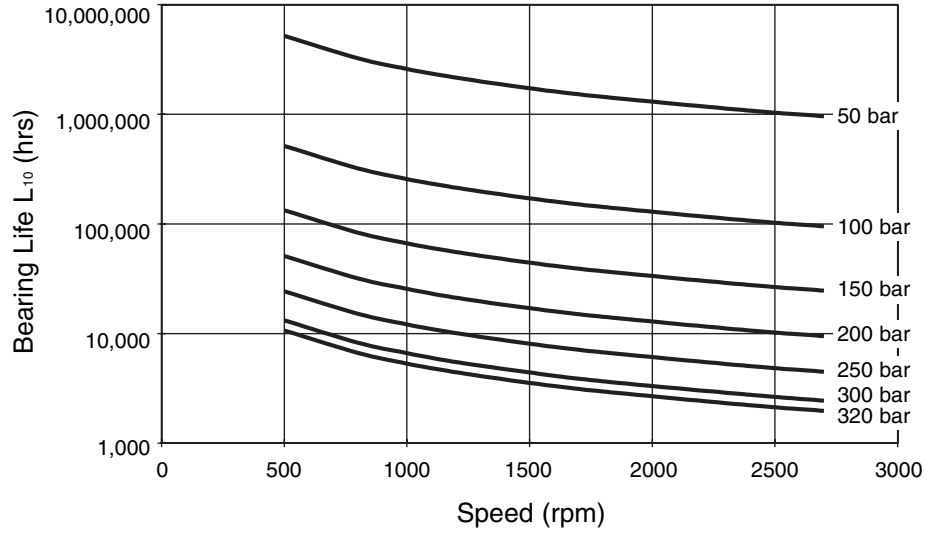

**K3VL140**

Note: Service and other life factors have unity value

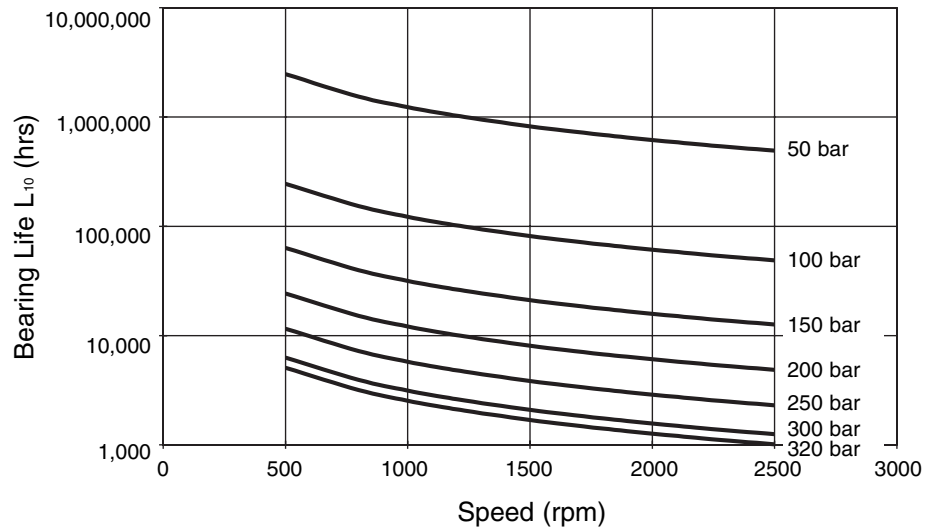

**Bearing Life (Full Displacement) (continued)**

**K3VL200**

Note: Service and other life factors have unity value

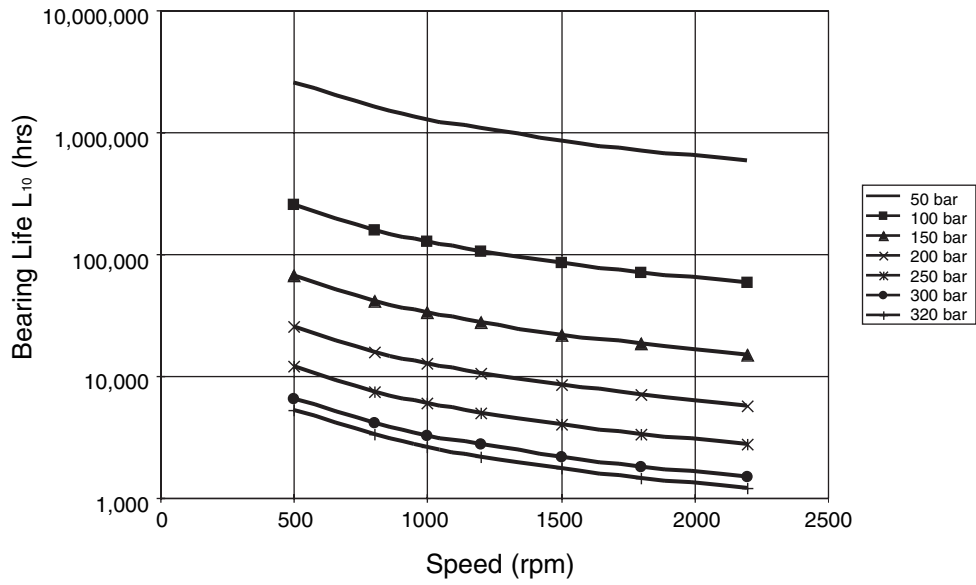



**Bearing Life (Industrial situation)**

**K3VL45**

Note: Service and other life factors have unity value

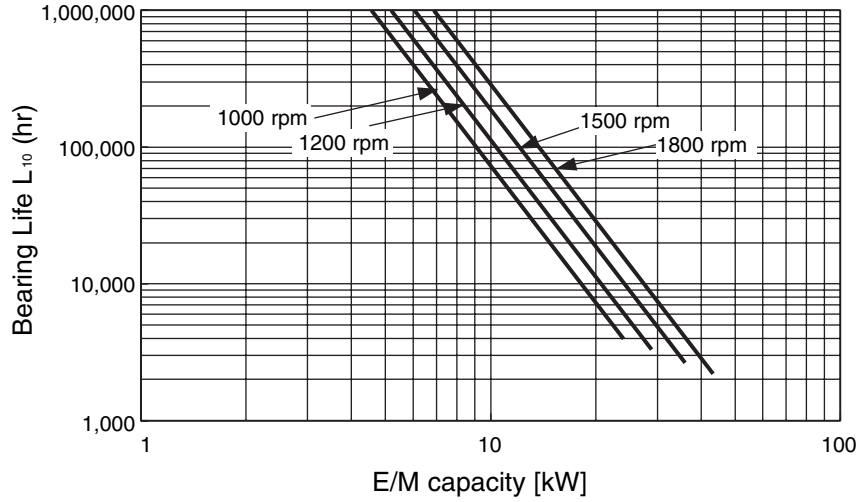

**K3VL80**

Note: Service and other life factors have unity value

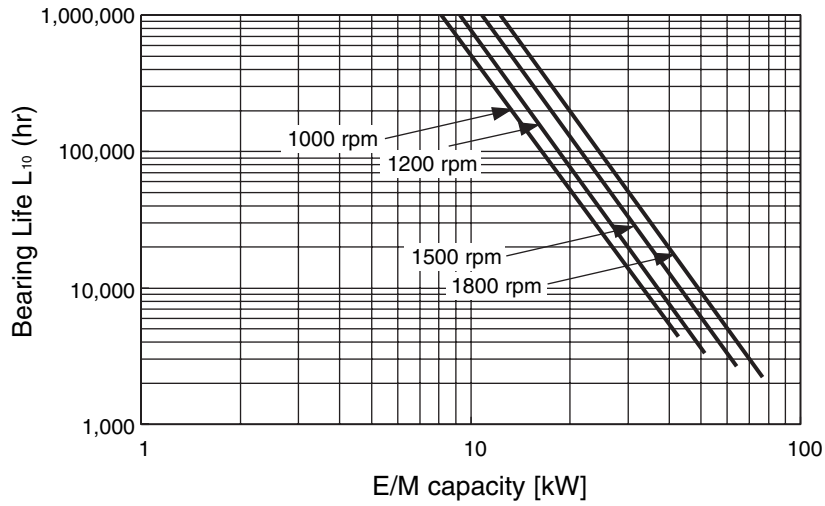

**Bearing Life (Industrial Situation) (continued)**

**K3VL112**

Note: Service and other life factors have unity value

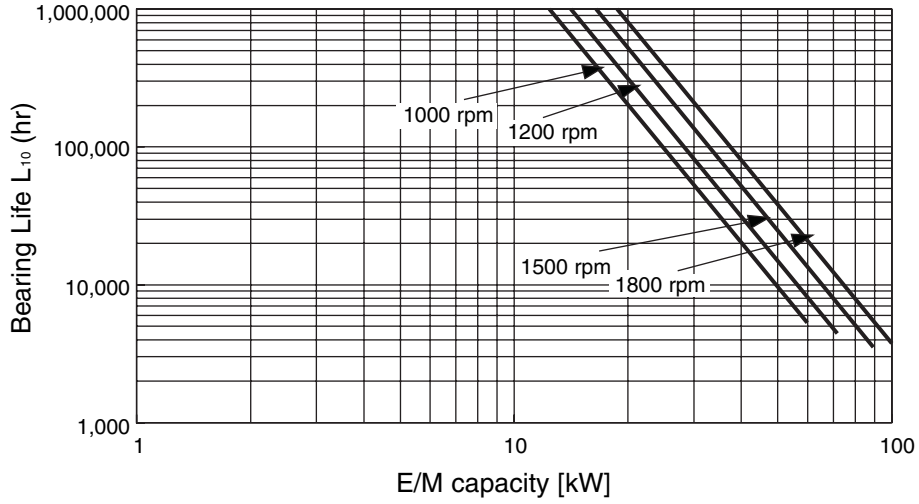

**K3VL140**

Note: Service and other life factors have unity value

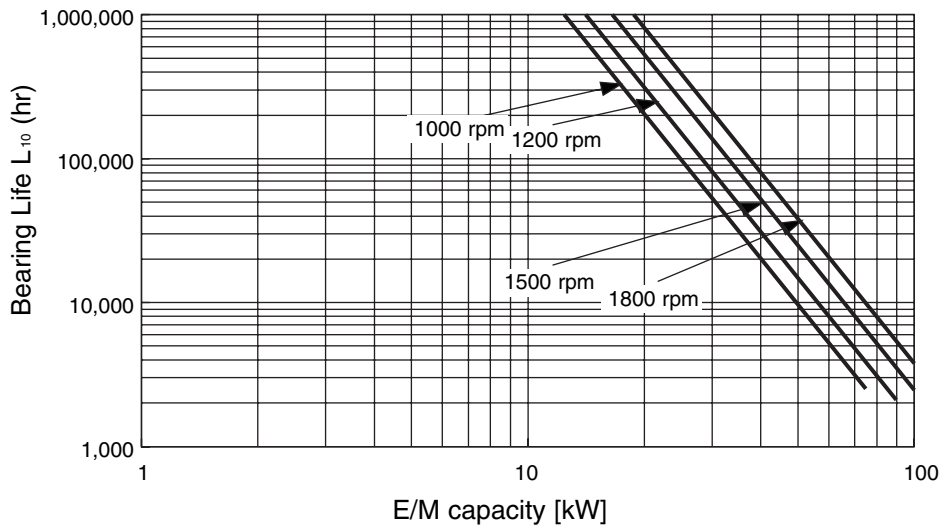

**Bearing Life (Industrial Situation) (continued)**

**K3VL200**

Note: Service and other life factors have unity value

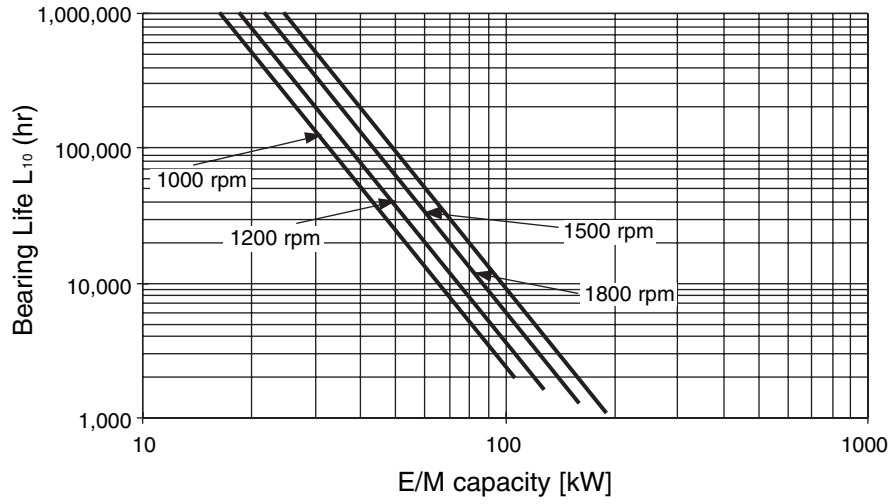

**Bearing Life (continued)**

**Bearing Life Correction Factors for Partial Displacement**

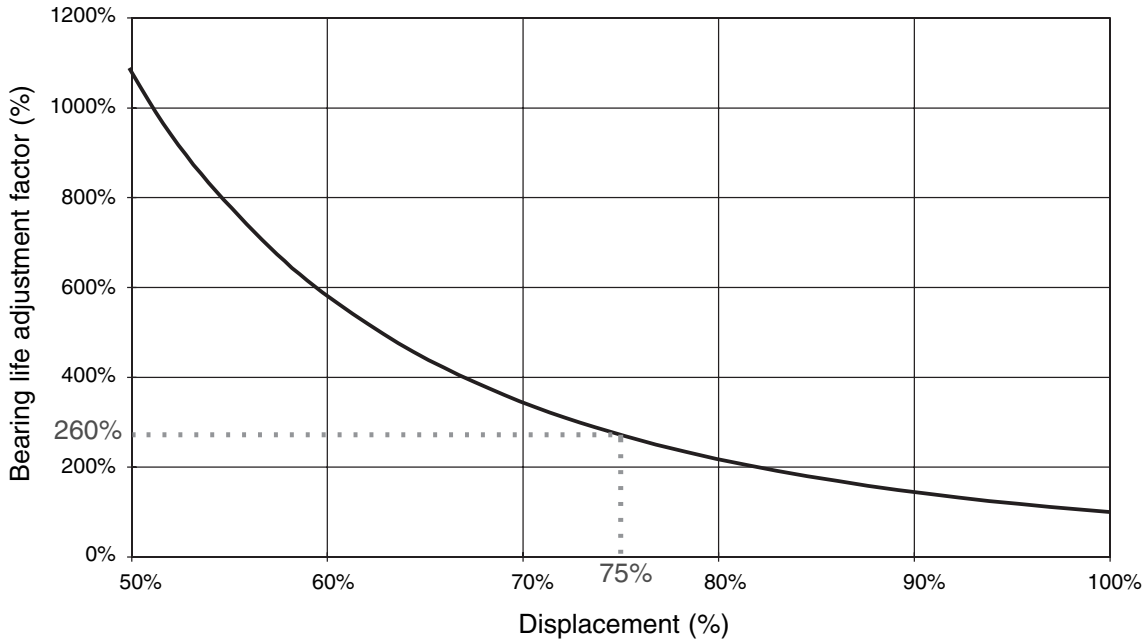

All bearing life curves on the previous pages refer to L10 life at full displacement. The foregoing curve is therefore to be used where duty cycle considerations require one to compute weighted life, which include partial displacement conditions.

For example as shown above if the bearing life at full displacement from the previous graphs was say 50,000 hours, then at the same operating condition with only 75% displacement the bearing life would be 260% of 50,000 hours or 130,000 hours.



**Radial Loading Capacity**

No axial shaft loading possible

Radial loading is achievable but in specific orientation:-

In addition because of the high bearing capacity of this front bearing, radial shaft loading can be allowed provided that its orientation is such that it is this front bearing that takes the additional load (See diagram below and the bearing life and radial loading curves).

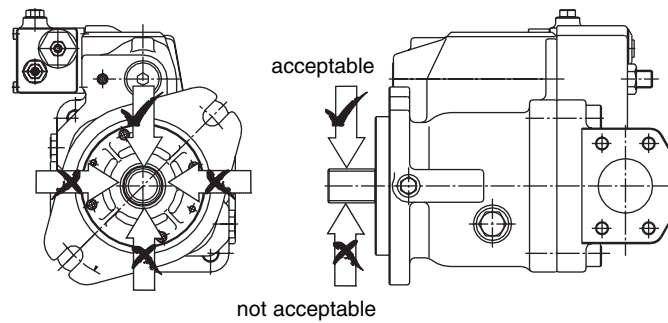

**Radial Loading Capacity (continued)**

**K3VL45 Radial Loading Capacity**

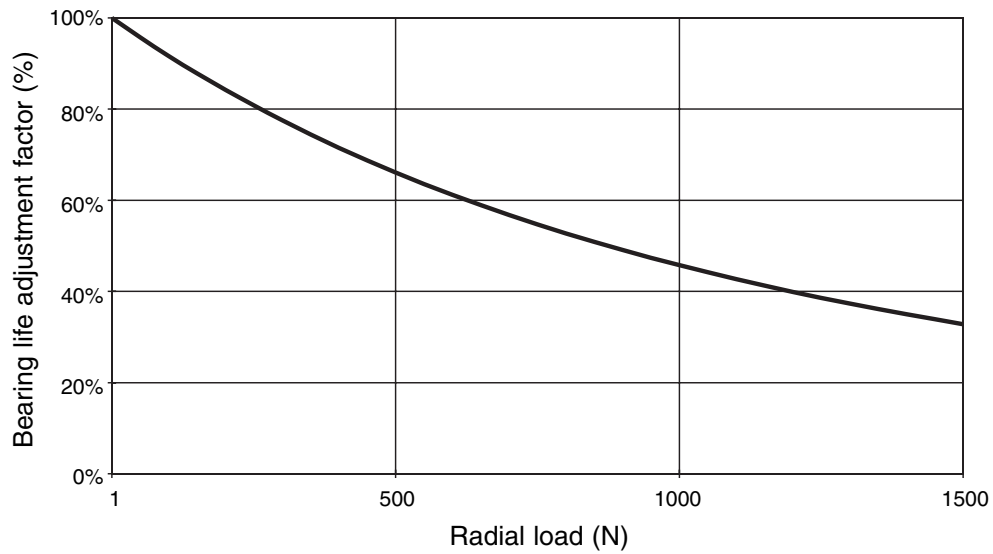

**K3VL80 Radial Loading Capacity**

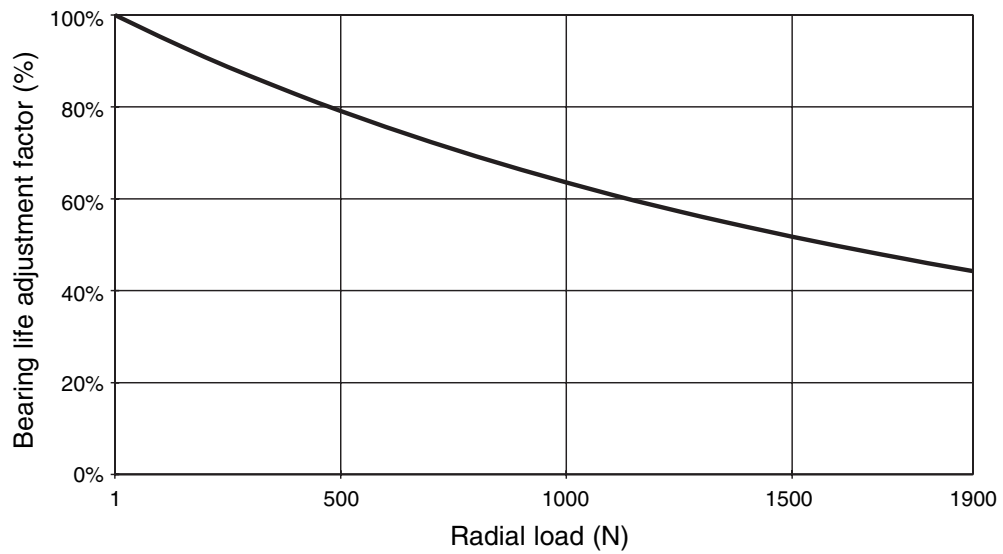

**Radial Loading Capacity (continued)**

**K3VL112 Radial Loading Capacity**

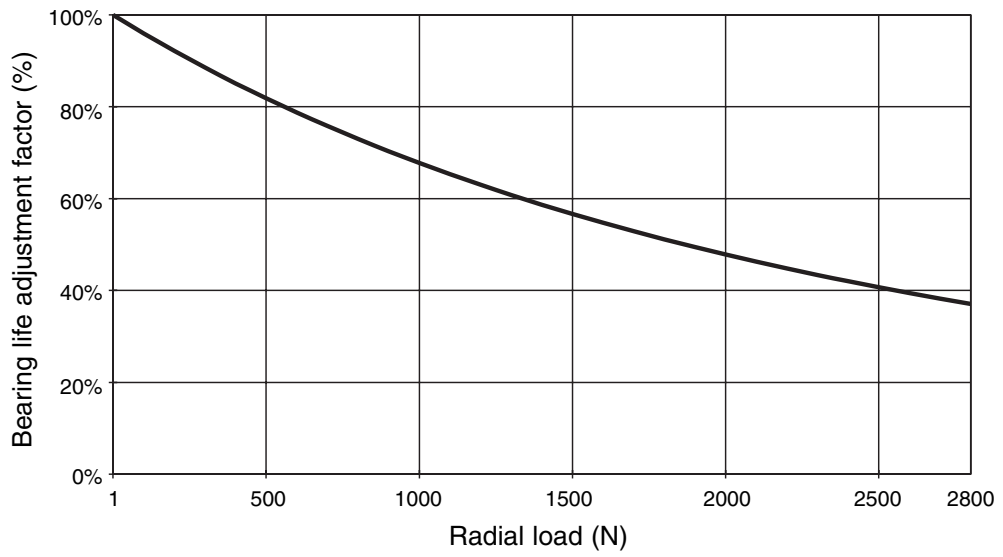

**K3VL140 Radial Loading Capacity**

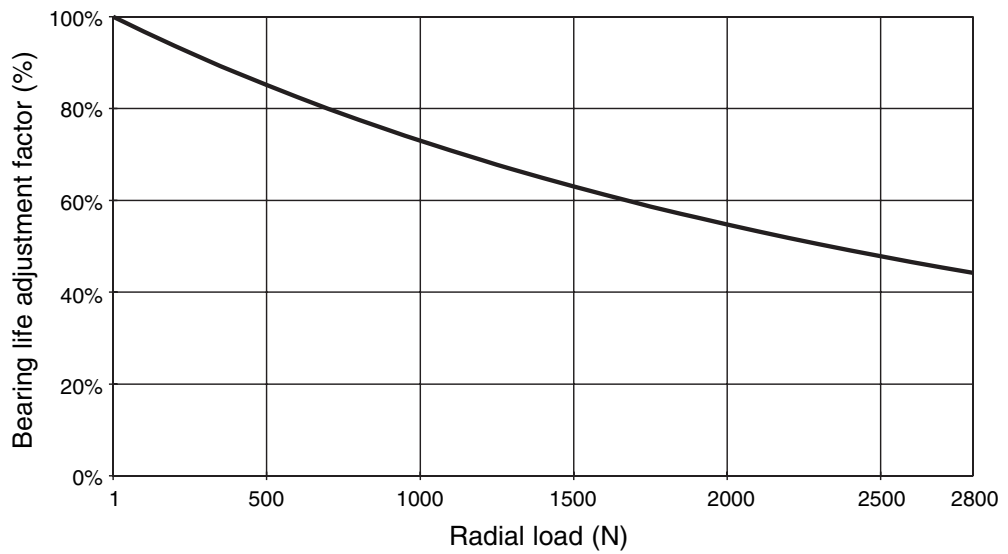

**Radial Loading Capacity (continued)**

**K3VL200 Radial Loading Capacity**

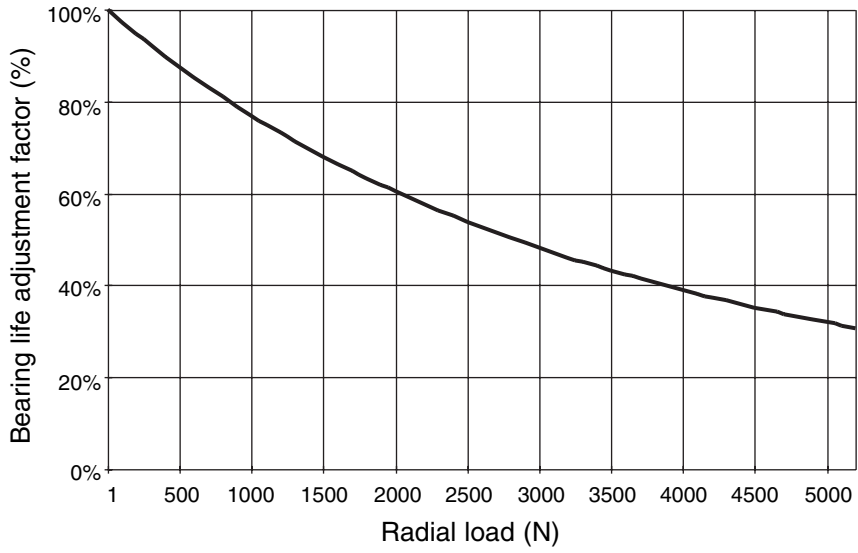

Model  
K3VL

Page  
32.64

Data Sheet  
P-1002/01.06



**Functional Description of Regulator**

Key to Hydraulic Circuit Annotations	
Annotation	Description
A <sub>1</sub>	Main pump delivery
A <sub>2</sub>	Auxiliary pump delivery
a <sub>1</sub>	Gauge port main pump delivery
a <sub>2</sub>	Gauge port auxiliary pump delivery
B <sub>2</sub>	Gear pump suction
B <sub>1</sub>	Main pump suction
b	Suction gauge port
Dr	Drain
Pi	Pilot pressure
Pc	Remote pilot port, Pressure compensator
Pi	Pilot port displacement control
P <sub>L</sub>	Load sense port
Psv	Pressure assist port
Ps	Inlet pressure

Note: The optional attached gear pump is recommended for all displacement control options. Hydraulic circuit diagrams illustrate the attached gear pump.

Regulator Code	Control Curves	Hydraulic Circuit
<p><b>LO/L1 Load Sense and Pressure Cut-off</b></p> <p>Pump displacement is controlled to match the flow requirement as a function of the system differential pressure (load pressure vs delivery pressure). In addition, there is a pressure cutoff function incorporated into the control. With the L1 option, the bleed-off orifice R4 is plugged.</p>		

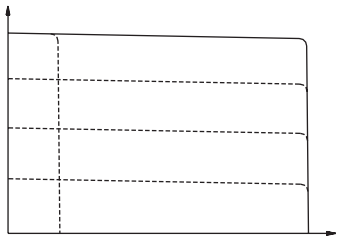
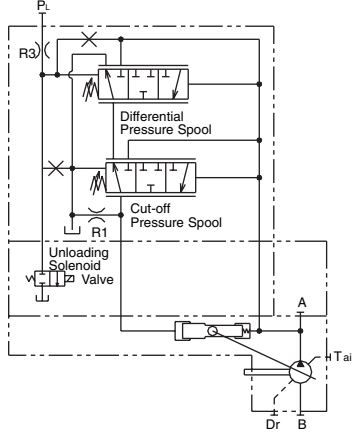
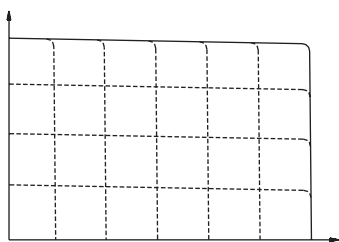
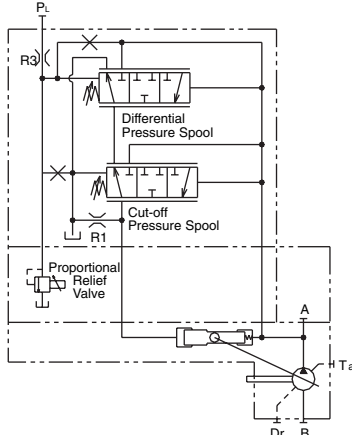

**Functional Description of Regulator (continued)**

Regulator Code	Control Curves	Hydraulic Circuit
<p><b>LN Load Sense and Pressure Cut-off with Integrated Unloading Valve</b></p> <p>An integrated unloading valve is sandwiched between the Load Sense regulator and pump to effectively de-stroke the swashplate when an electric signal is provided.</p>		
<p><b>LV Load Sense and Pressure Cut-off with Integrated Proportional Relief Valve</b></p> <p>An integrated proportional relief valve is sandwiched between the Load Sense regulator and pump to control the maximum pressure setting by varying an electric signal to the valve.</p> <p>A separate amplifier is required.</p>		

**Functional Description of Regulator (continued)**

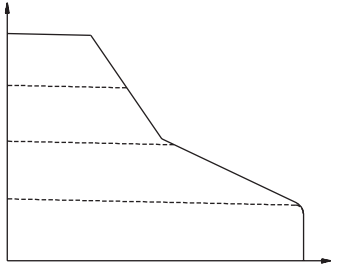
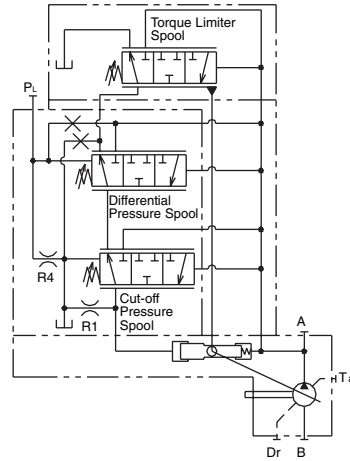
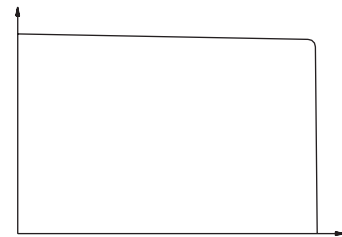
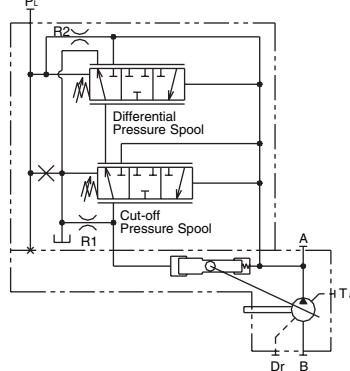
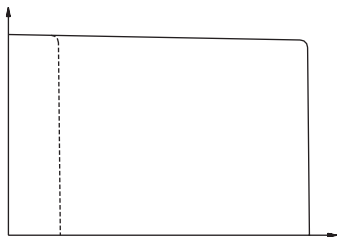
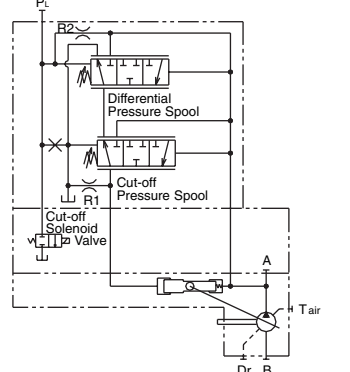
Regulator Code	Control Curves	Hydraulic Circuit
<p><b>L0/L1 Load Sense and Pressure Cut-off with Torque Limiting</b></p> <p>L0/L1 control functions as previously noted.</p> <p>In response to a rise in delivery pressure the swashplate angle is decreased, restricting the input torque. This regulator prevents excessive load against the prime mover.</p> <p>The torque limit control module is comprised of two springs that oppose the spool force generated by the system pressure. By turning an outer and inner spring adjustment screw, the appropriate input torque limit can be set.</p>		
<p><b>PO Pressure Cut-off</b></p> <p>As system pressure rises to the cut-off setting, the swashplate de-strokes to prevent the system pressure from exceeding the compensator setting. It is imperative that a safety relief valve be installed in the system.</p> <p>Note: By connecting the Pc port to a remote pressure control, variable pump pressure control can be achieved.</p>		
<p><b>PN Pressure Cut-off with Integrated Unloading Valve</b></p> <p>An integrated unloading valve is sandwiched between the Pressure Cut-off regulator and pump to effectively de-stroke the swashplate when an electric signal is provided.</p>		

**Functional Description of Regulator (continued)**

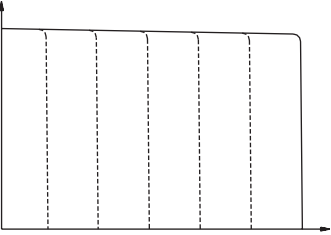
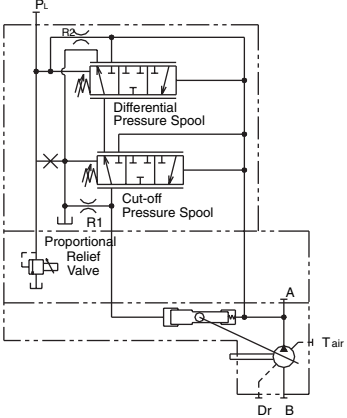
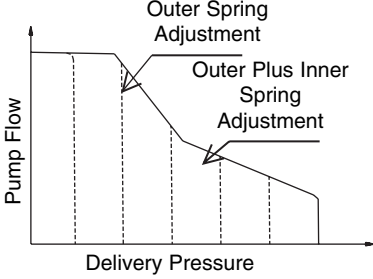
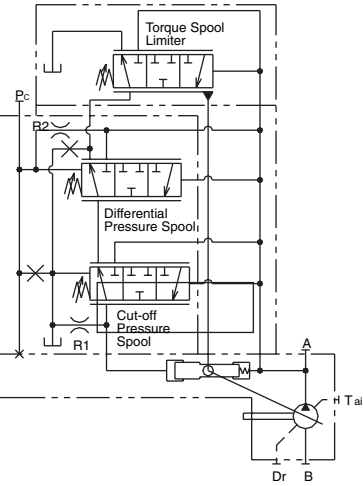
Regulator Code	Control Curves	Hydraulic Circuit
<p><b>PV Pressure Cut-off with Integrated Proportional Relief Valve</b></p> <p>An integrated proportional relief valve is sandwiched between the Pressure Cut-off regulator and the pump to control the maximum pressure setting by varying an electric signal to the valve.</p> <p>A separate amplifier is required.</p>		
<p><b>P0/1 Pressure Cut-off with Torque Limiting</b></p> <p>P0/P1 control functions as previously noted. In response to a rise in delivery pressure the swashplate angle is reduced, restricting the input torque. This regulator prevents excessive load against the prime mover.</p> <p>The torque limit control module is comprised of two springs that oppose the spool force generated by the system pressure. By turning an outer and inner spring adjustment screw, the appropriate input torque limit can be set.</p> <p>Note: By connecting the Pc port to a remote pressure control, variable pump pressure control can be achieved as indicated below.</p>		

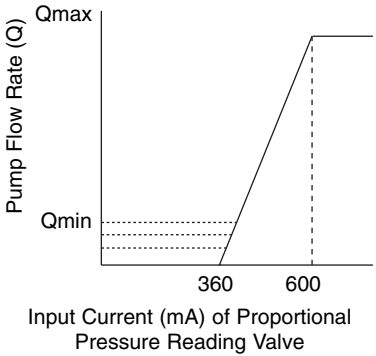
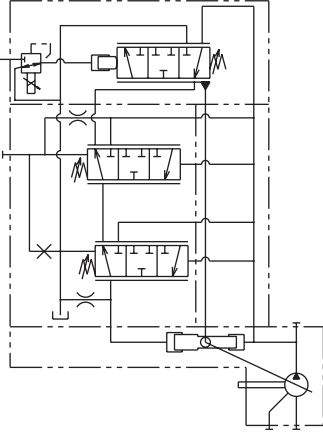
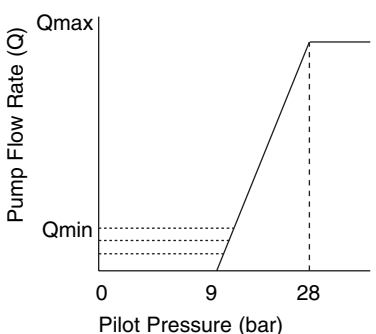
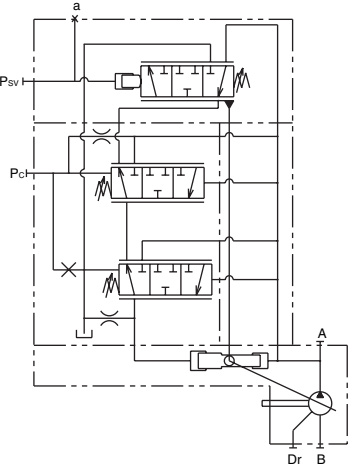

**Functional Description of Regulator (continued)**

Regulator Code	Control Curves	Hydraulic Circuit
<p><b>/1-E0 Electrical Displacement Control</b></p> <p>Varying the input current signal to the pump controller's electronic proportional pressure reducing valve (PPRV) allows the user to control the pump displacement. As the current signal to the PPRV increases, the pump displacement increases proportionally.</p> <p>Note: An external pressure supply of 40 bar is required at the PSV Port (50bar max).</p>		
<p><b>/1-Q0 Pilot Operated Displacement Control</b></p> <p>Varying the input pressure signal to the PSV port allows the user to control the pump displacement. As the pressure signal to the PSV increases, the pump displacement increases proportionally.</p>		

**Functional Description of Regulator (continued)**

Regulator Code	Hydraulic circuit
<p><b>Parallel control (Without torque limiter)</b> /1-PP Parallel pressure compensation control</p> <p>As system pressure rises to the Cut-off setting, the swashplate de-strokes to prevent the system pressure exceeding the compensator setting. It is imperative that a safety relief valve be installed in the system. Note: By connecting the Pc ports together multiple pumps in parallel operation is achieved.</p>	

**Torque Limiter Settings**

The following tabulations show the power limitation at various electric motor speeds for a specific pump. When selecting a control setting please ensure that the power limitation of a particularly sized electric motor to your national standard is not exceeded.

970 rpm				
Power (KW)	Pump Frame Size			
	45	80	112	140
5.5	L3			
7.5	L1	L6		
11	M1	L2		
15	H3	M4	L3	L6
18.5		M1	M4	L3
22		H3	M2	L1
30		H1	H4	M2
37			H2	H4
45				H2

1150 rpm				
Power (KW)	Pump Frame Size			
	45	80	112	140
7.5	L2			
11	M3	L4		
15	H4	L1	L4	
18.5	H2	M3	L2	L5
22		M1	M4	L3
30		H2	M1	M3
37			H3	M1
45			H2	H4
55				H2

1450 rpm				
Power (KW)	Pump Frame Size			
	45	80	112	140
7.5	L4			
11	L1	L6		
15	M2	L3		
18.5	H4	L1	L4	
22	H3	M4	L3	L6
30		H4	M3	L2
37		H2	M1	M3
45		H1	H4	M2
55			H2	H4
75				H1

1750 rpm				
Power (KW)	Pump Frame Size			
	45	80	112	140
11	L2			
15	M4	L5		
18.5	M2	L3		
22	H4	L1	L4	
30	H1	M2	L1	L4
37		H4	M3	L2
45		H2	M1	M3
55		H1	H4	M2
75			H1	H3
90				H1

K3VL200				
KW	970	1150	1450	1750
3.7				
5.5				
7.5				
11				
15				
22	L4			
30	L2	L3		
37	M3	L1	L3	
45	M1	M3	L2	L3
55	H5	M1	M3	L2
75	H1	H3	H6	M2
90		H1	H4	H6
110			H2	H4
132				H2

 = Exceeds SAE C Max Input Torque (400NM)



**Installation**

**Recommended Pump Mounting**

The pump should be mounted horizontally with the case drain piping initially rising above the level of the pump before continuing to the tank as shown in the illustration below. Do not connect the drain line to the suction line.

The uppermost drain port should be used and the drain piping should be equal or larger in size than the drain port to minimise pressure in the pump case. The pump case pressure should not exceed 1 bar as shown in the illustration below. (Peak pressure should never exceed 4 bar.)

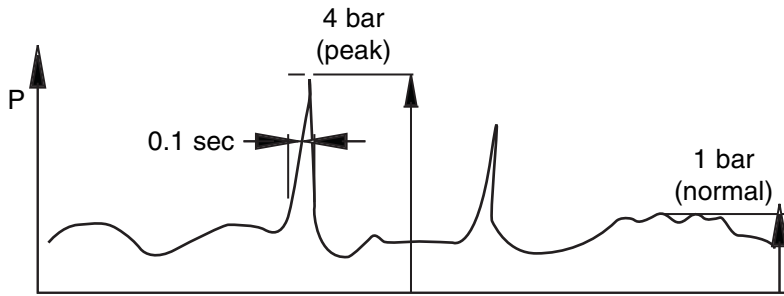

**Mounting the Pump Above the Tank**

Suction line

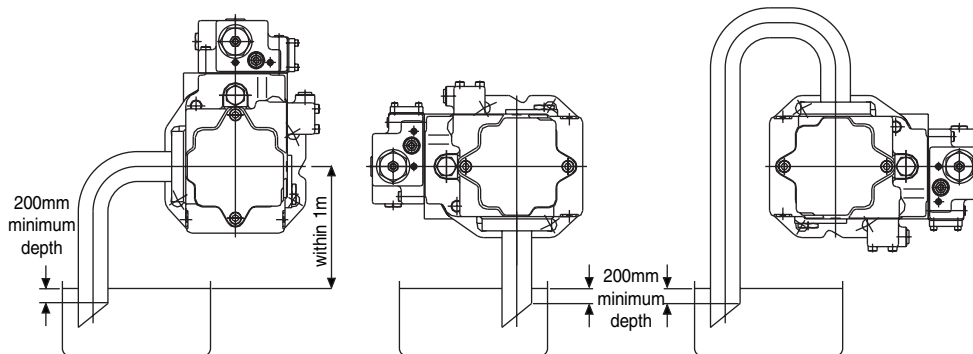

Drain line

"Goose neck" configuration is required, this prevents direct drop of oil level in the pump case.

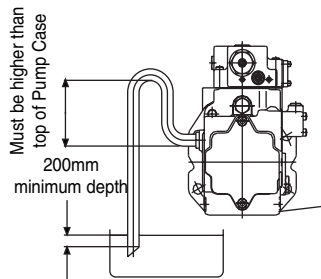

**Cautions**

- A) Suction and drain pipes must be immersed by 200mm minimum from the lowest oil level under operating conditions.
- B) Height from the oil level to the centre of the shaft must be within 1m.
- C) The oil in the pump case must be refilled when the pump has not been operated for one month or longer.





**Installation (continued)**

**Mounting the Pump Vertically (shaft up)**

For applications requiring vertical installation (shaft up) please remove the air bleed plug and connect piping as shown in the illustration below.

The oil level in the tank should be higher than the pump-mounting flange as shown in illustration [a] below. If the oil level in the tank is lower than the pump mounting flange then forced lubrication is required through the air bleed port 1 ~ 2 l/min.

When installing the pump in the tank and submerged in the oil, open the drain port and air bleed port to provide adequate lubrication to the internal components.

When installing the pump outside the tank run piping for the drain and air bleed ports to tank (see illustration [c]). If the drain or air bleed piping rise above the level of oil (see illustration [b]) fill the lines with oil before operation.

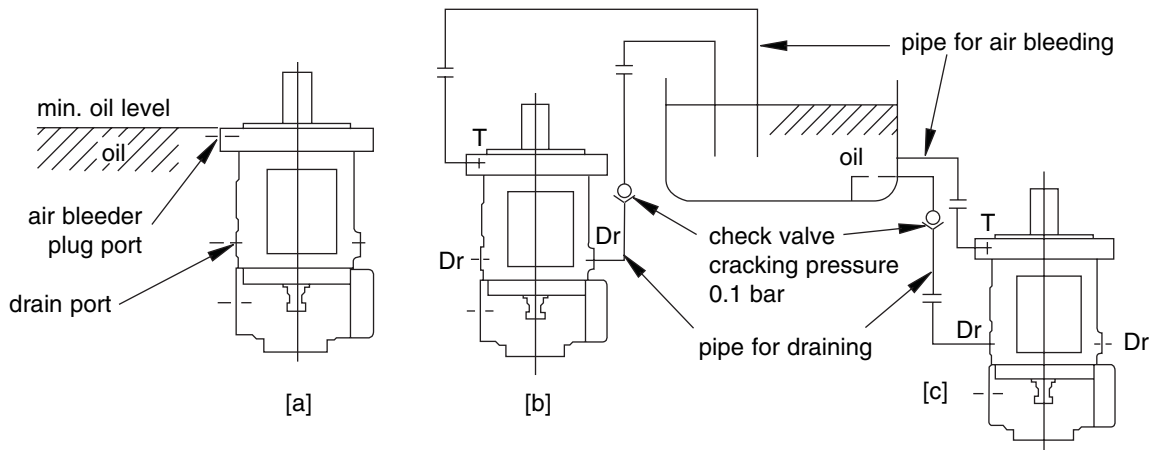

A check valve with cracking pressure of 0.1 bar should be fitted to the case drain line as shown. Recommended Kawasaki check valves are as follows: (refer to Kawasaki industrial valve information - data sheet C1001)

Model	Recommended Kawasaki check valve
K3VL45	C10G – 10/01-*
K3VL80	C15G – 10/01-*
K3VL112	C15G – 10/01-*
K3VL140	C15G – 10/01-*
K3VL200	C15G – 10/01-*



**Drive Shaft Coupling**

Use a flexible coupling to connect the pump shaft to an engine flywheel or electric motor shaft. Alignment should be within 0.05mm TIR as shown in the illustration below.

Do not apply any radial or axial loading to the pump shaft. For applications where radial or side loads exist please contact Kawasaki Precision Machinery (UK) Ltd. for recommendations.

Do not force the coupling on or off the pump shaft. Use the threaded hole in the end of the pump shaft to fix or remove the coupling.

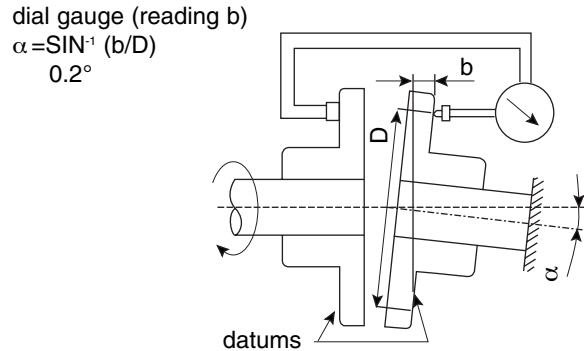
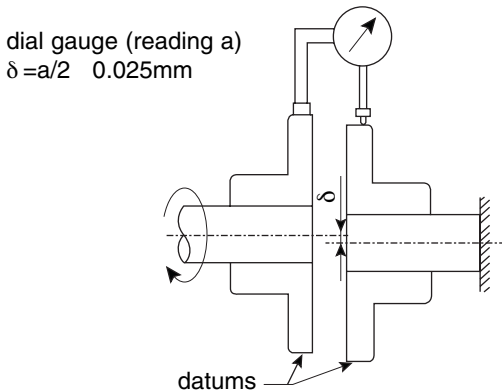

For engine drives a split type pinch bolt drive flange and flexible coupling is recommended.

**Through Drive Limitations**

Apart from predefined maximum throughput limitations, one must also ensure that to prevent a possible excessive bending moment occurring that the maximum combined bending moment of the combination is not exceeded as determined in the following expression

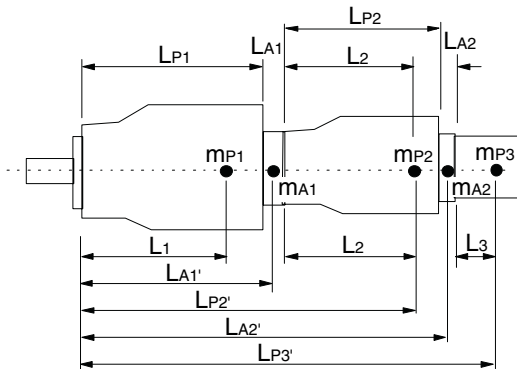

- $M_{PX}$  = mass of pump [kg]
- $L_{PX}$  = length of pump [mm]
- $L_X$  = distance of CofG from pump mounting face [mm]
- $M_{AX}$  = mass of adaptor kit [kg]
- $L_{AX}$  = width of adaptor kit [mm]

$$\begin{aligned} \text{Bending Moment} = & ((L_1.m_{P1}) + (L_{A1}.m_{A1}) + (L_{P2}.m_{P2}) + (L_{A2}.m_{A2}) + L_{P3}.m_{P3} + \dots) / 102 \text{ [Nm]} \\ & ((L_1.m_{P1}) \\ & + (L_{P1} + (L_{A1}/2)).m_{A1} \\ & + (L_{P1} + L_{A1} + L_2).m_{P2} \\ & + (L_{P1} + L_{A1} + L_{P2}(L_{A2}/2)).m_{A2} \\ & + (L_{P1} + L_{A1} + L_{P2} + L_{A2}).m_{P3} \\ & + \dots) / 102 \end{aligned}$$



**Through Drive Limitations (continued)****Pump overall length [mm] (Lp)**

Pump Size	Single Pump	Stock Pump
	Type "0"	Type "S"
45/60	244	244
80	272	272
112/140	308	308
200	359	359

Pump Size	Maximum Permissible Bending Moment (Nm)
45/60	137
80	244
112/140	462
200	930

**Pump approximate weight [kg] (Mp)**

Pump Size	Without torque limiter		With torque limiter	
	Single Pump	Stock Pump	Single Pump	Stock Pump
	Type "0"	Type "S"	Type "0"	Type "S"
45/60	25	28	27	30
80	35	38	37	40
112/140	65	69	67	71
200	95	103	97	105

Adaptor Kits weight (Ma) & Width (La)			
Pump size	Adaptor Kit	Weight (Max)	Width (Lax)
45	SAE "A"	0	0
	SAE "B" & "BB"	2	20
80	SAE "A"	0	0
	SAE "B" & "BB"	3	20
	SAE "C"	4	24.5
112 & 140	SAE "A"	0	0
	SAE "B" & "BB"	3	25
	SAE "C" & "CC"	5	30
200	SAE "D"	10	43
	SAE "A"	1	6
	SAE "B" & "BB"	8	25
	SAE "C" & "CC"	8	30
	SAE "D"	10	38
	SAE "E"	15	38

**Pump CofG from mount [mm] (L)**

Pump Size	Single Pump	Stock Pump
	Type "0"	Type "S"
45/60	120	120
80	130	130
112/140	150	150
200	190	190

**Electrical Displacement Control Application**

The standard minimum flow setting for the K3VL pump is 0.5-3.0% of the maximum pump delivery. The pumps minimum displacement stop can be modified if a greater minimum flow rate is required. In order for the electronic displacement control to function, a minimum pilot pressure for 40 bar must be supplied to the Psv port on the regulator. A gear pump attached to the rear of the K3VL pump or an external pressure source can be used to provide the required pilot pressure.

**Proportional Pressure Reducing Valve Specification**

Maximum Pilot Pressure	: 50 bar	If higher pressure required contact KPM
Max Flow	: 10 l/min	
Hydraulic oil	: Mineral oil	
Oil temp range	: -20~+90°C	
Viscosity range	: 5~500 cst	
Allowable contamination	: NAS grade 10 and below	
Electrical specifications,		
Rated current	: 700 mA	
Recommended dither	: 80 Hz / 200 mAp-p	
Coil resistance	: 17.5 (at 20°C)	
Ambient temperature range	: -30~+80°C	
Water resistance	: According to JIS D 0203 S2	



**Unit Dimensions**

**K3VL45 Installation**

K3VL45 with Cut-Off / Load Sense Control  
& Torque Limit Module (Clockwise Rotation)

Note  
for counter clockwise rotation,  
the suction port "B" and the  
delivery port "A" are reversed

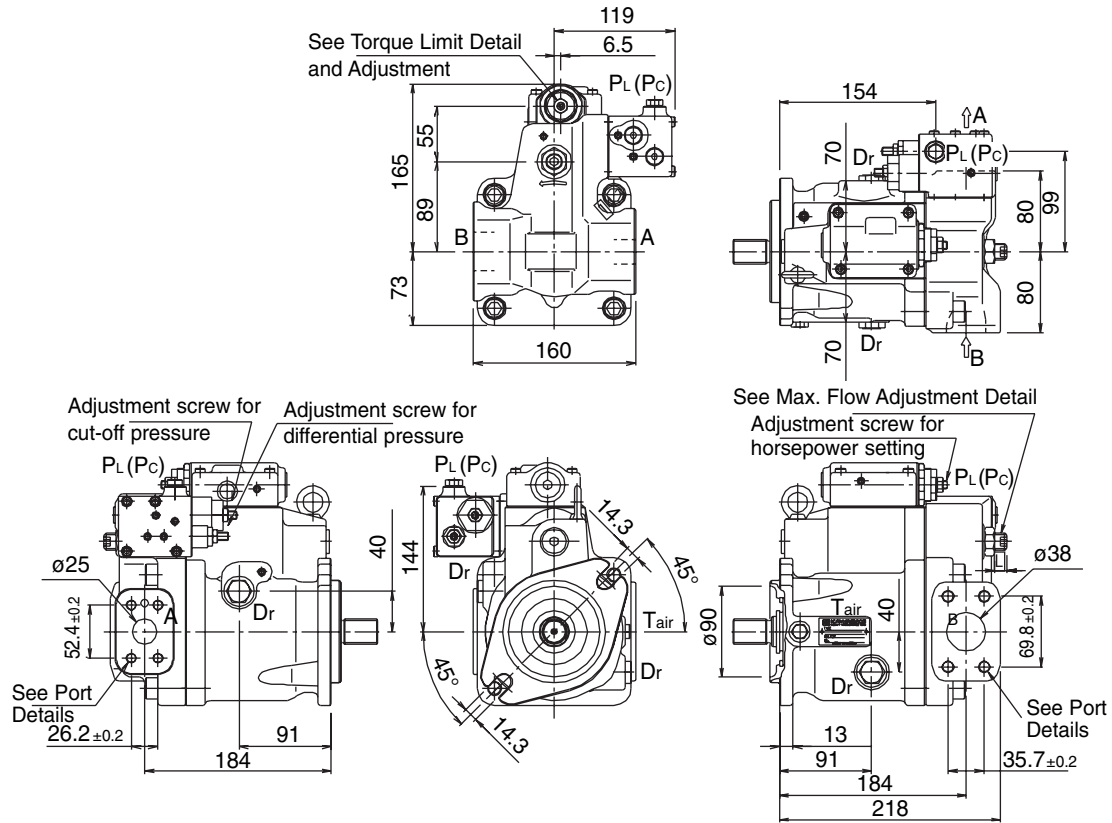

Unit Dimensions (continued)

K3VL45 Mounting Flange and Shaft Options

SAE Type

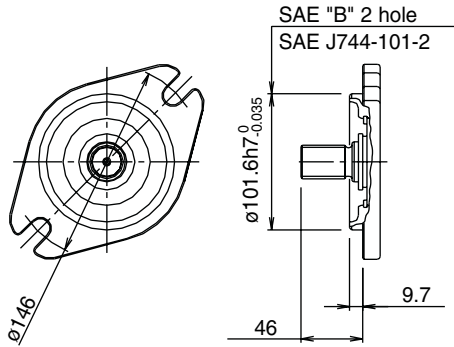

ISO Type

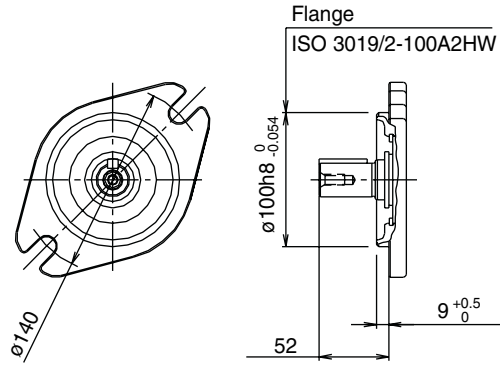

SAE Spline Shaft

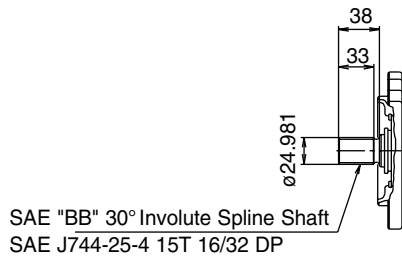

SAE Straight Shaft

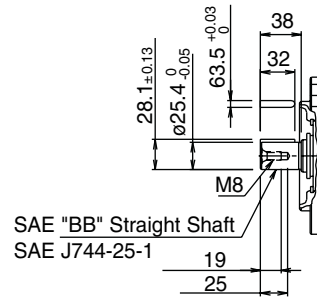

ISO Straight Shaft

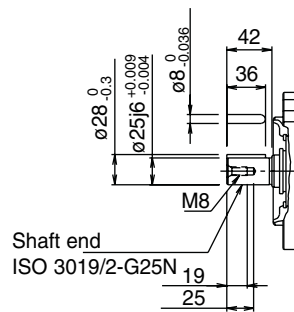

**Unit Dimensions (continued)**

**K3VL45 Rear Port**

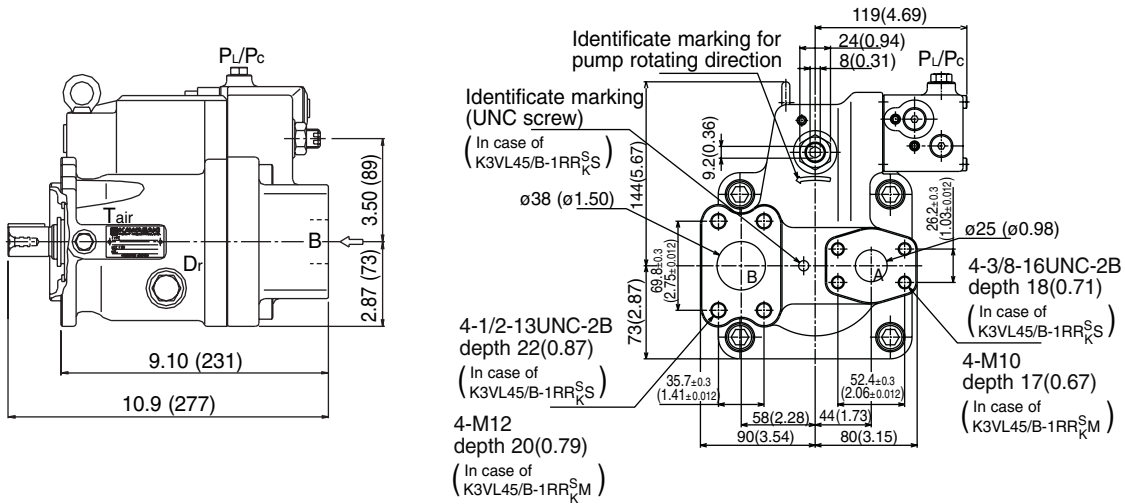

**K3VL45 Porting Details**

**Main SAE Flanged Ports**

Des.	Port Name	Port Size	Tightening Torque (Nm)	Flange Threads
------	-----------	-----------	------------------------	----------------

UNF Threaded Version ("S" in position 9 of model code)

A	Delivery Port	SAE J518C Std pressure (code 61) 1"	57	3/8-16UNC-2B x 18mm
B	Suction Port	SAE J518C Std pressure (code 61) 1 1/2"	98	1/2-13UNC-2B x 22mm

Metric Version ("M" in position 9 of model code)

A	Delivery Port	SAE J518C Std pressure (code 61) 1"	57	M10 x 17
B	Suction Port	SAE J518C Std pressure (code 61) 1 1/2"	98	M12 x 20

**Auxiliary Ports**

Des.	Port Name	Port Size	Tightening Torque (Nm)
------	-----------	-----------	------------------------

SAE Version ("S", "K", "U" or "T" in position 8 of model)

Dr	Drain Port (x2)	SAE J1926/1 Straight thread O ring boss 1/2" OD Tube 3/4-16UNF-2B	98
PL PC	Load Sensing Port Pressure Control Port	SAE J1926/1 Straight thread O ring boss 1/4" OD Tube 7/16-20UNF-2B	12
Tair	Air Bleeder Port	SAE J1926/1 Straight thread O ring boss 1/4" OD Tube 7/16-20UNF-2B	12

ISO Version ("M" in position 8 of model code)

Dr	Drain Port (x2)	M22 x 1.5 DIN 3852	98
PL PC	Load Sensing Port Pressure Control Port	M14 x 1.5 DIN 3852	25
Tair	Air Bleeder Port	M14 x 1.5 DIN 3852	25



**Unit Dimensions (continued)**

**K3VL45 Through Drive Options**

Through Drive "A"

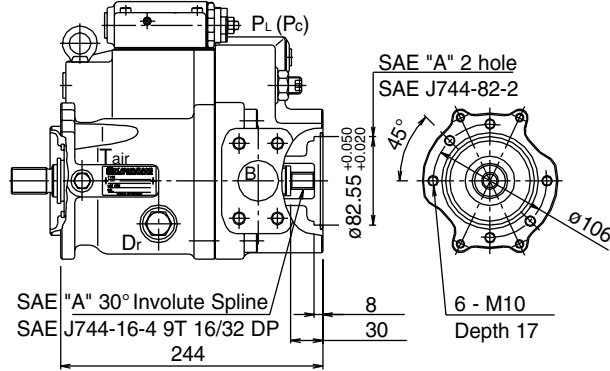

Through Drive "B"

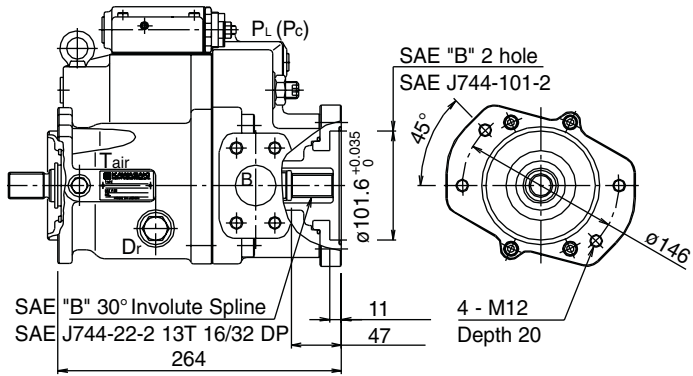

Through Drive "BB"

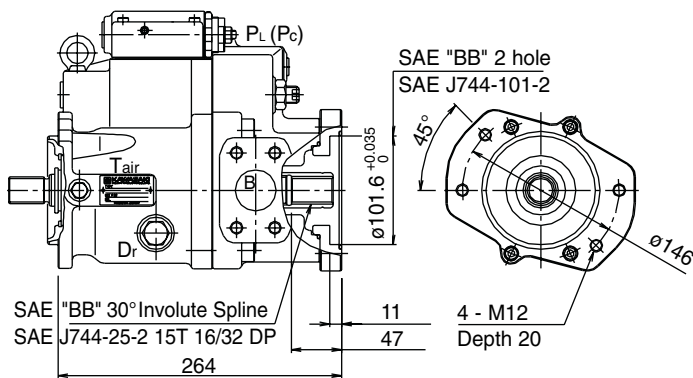

**Unit Dimensions (continued)**

**K3VL45 Adaptor Kits**

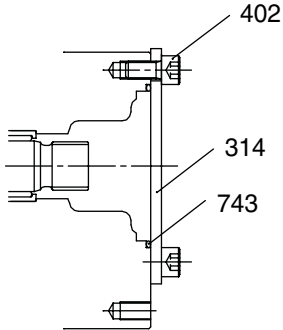

Cover Kit

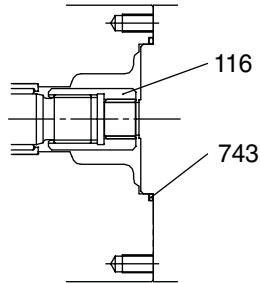

SAE "A"  
T/D Kit

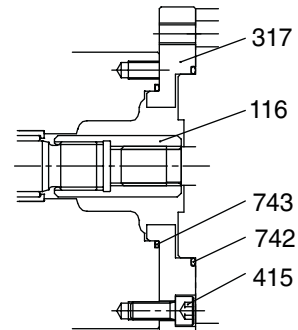

SAE "B" & "BB"  
T/D Kit

No	Part Name	QTY	Cover Kit	SAE "A" T/D Kit	SAE "B" T/D Kit	SAE "BB" T/D Kit
—	T/D Kit		29L8TN	29L4TA	29L4TB	29L4T2
743	O-Ring	1	00RBG85	00RBG85	00RBG85	00RBG85
742	O-Ring	1	—	—	00RBG105	00RBG105
415	Screw Hex SHC	4	—	—	0SBM825	0SBM825
402	Screw Hex SHC	2	0SBM1020	—	—	—
317	Subplate	1	—	—	2924750-0358	2924750-0358
314	Cover	1	2923150-0316	—	—	—
116	Coupling	1	—	2903150-0264	2903150-0265	2903150-0266





**Unit Dimensions (continued)**

**K3VL80 Installation**

K3VL80 with Cut-Off / Load Sense Control  
& Torque Limit Module (Clockwise Rotation)

Note  
for counter clockwise rotation,  
the suction port "B" and the  
delivery port "A" are reversed

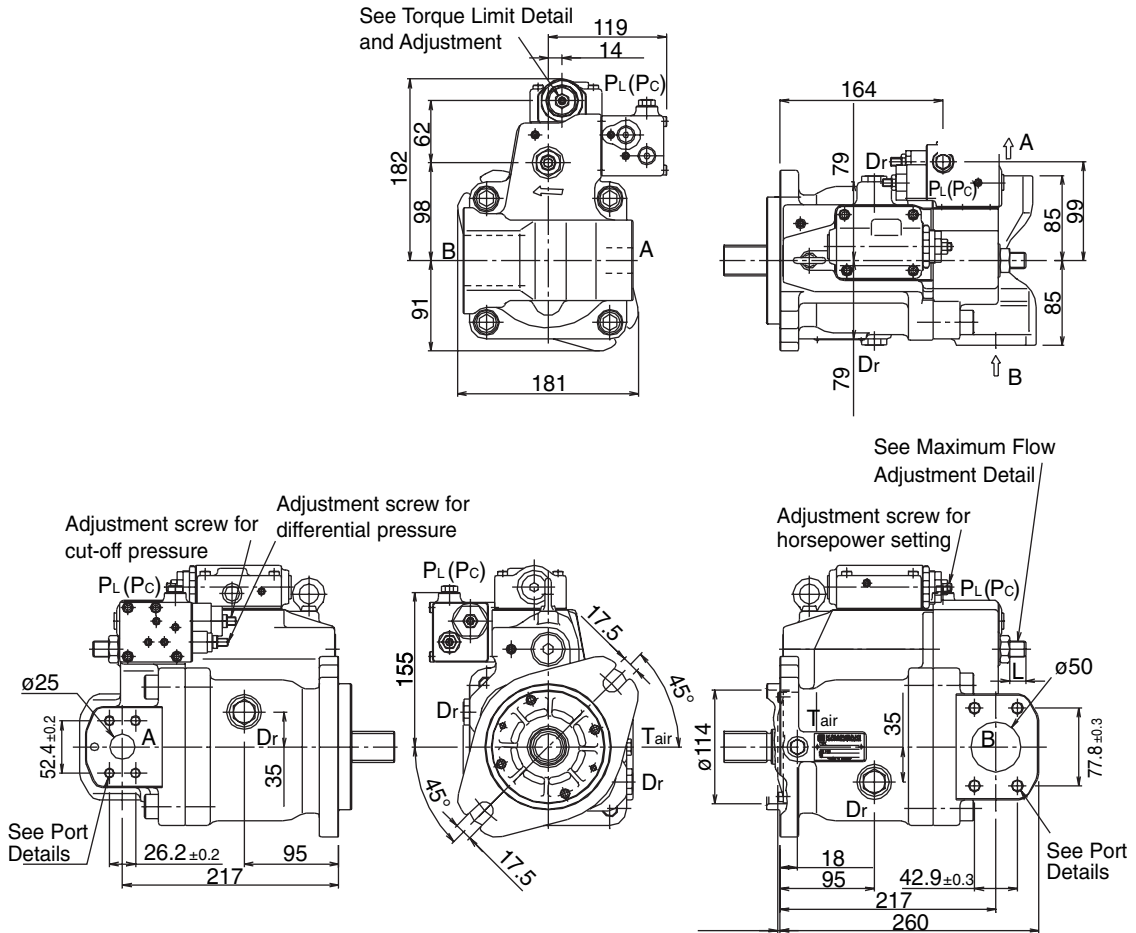

Unit Dimensions (continued)

K3VL80 Mounting Flange and Shaft Options

SAE Type

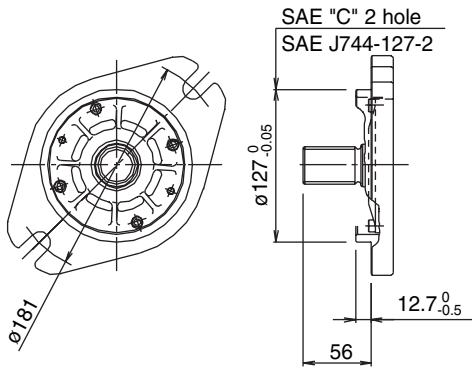

ISO Type

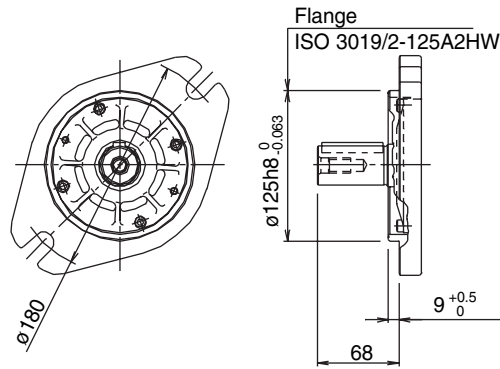

SAE Spline Shaft

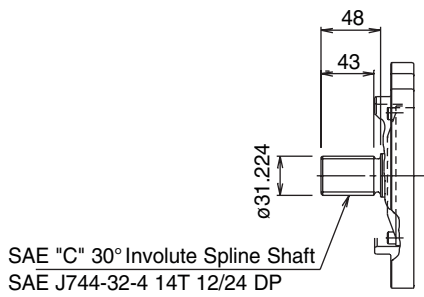

SAE Straight Shaft

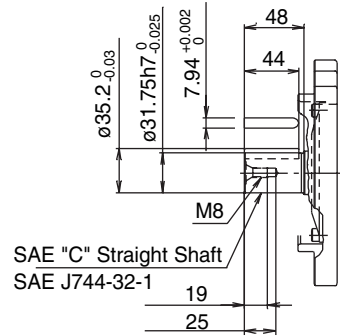

ISO Straight Shaft

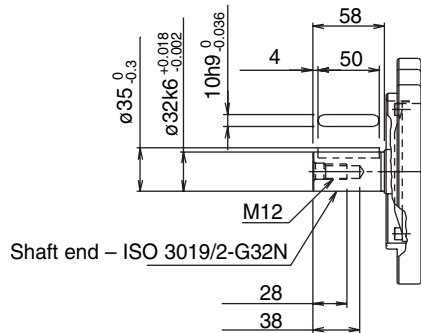

**Unit Dimensions (continued)**

**K3VL80 Rear Port Option**

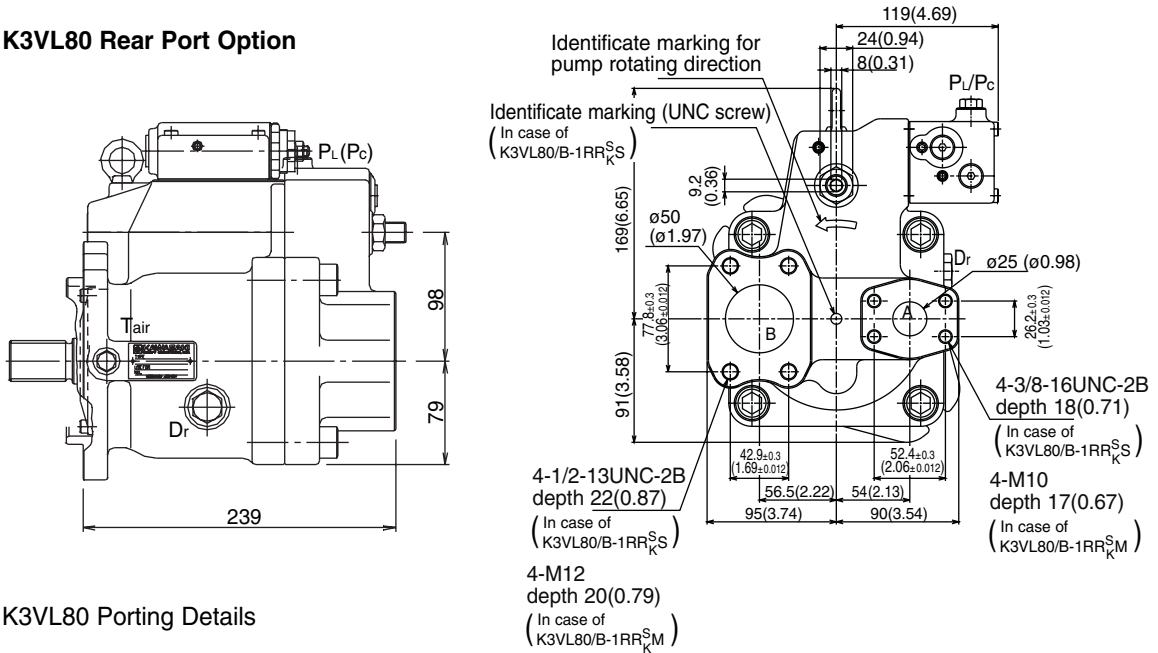

**K3VL80 Porting Details**

**Main SAE Flanged Ports**

Des.	Port Name	Port Size	Tightening Torque (Nm)	Flange Threads
------	-----------	-----------	------------------------	----------------

UNF Threaded Version ("S" in position 9 of model code)

A	Delivery Port	SAE J518C Std pressure (code 61) 1"	57	3/8-16UNC-2B x 18mm
B	Suction Port	SAE J518C Std pressure (code 61) 2"	98	1/2-13UNC-2B x 22mm

Metric Version ("M" in position 9 of model code)

A	Delivery Port	SAE J518C Std pressure (code 61) 1"	57	M10 x 17
B	Suction Port	SAE J518C Std pressure (code 61) 2"	98	M12 x 20

**Auxiliary Ports**

Des.	Port Name	Port Size	Tightening Torque (Nm)
------	-----------	-----------	------------------------

SAE Version ("S", "K", or "T" in position 8 of model)

Dr	Drain Port (x2)	SAE J1926/1 Straight thread O ring boss 1/2" OD Tube 3/4-16UNF-2B	98
PL PC	Load Sensing Port Pressure Control Port	SAE J1926/1 Straight thread O ring boss 1/4" OD Tube 7/16-20UNF-2B	12
Tair	Air Bleeder Port	SAE J1926/1 Straight thread O ring boss 1/4" OD Tube 7/16-20UNF-2B	12

ISO Version ("M" in position 8 of model code)

Dr	Drain Port (x2)	M22 x 1.5 DIN 3852	98
PL PC	Load Sensing Port Pressure Control Port	M14 x 1.5 DIN 3852	25
Tair	Air Bleeder Port	M14 x 1.5 DIN 3852	25



**Unit Dimensions (continued)**

**K3VL80 Through Drive Options**

Through Drive "A"

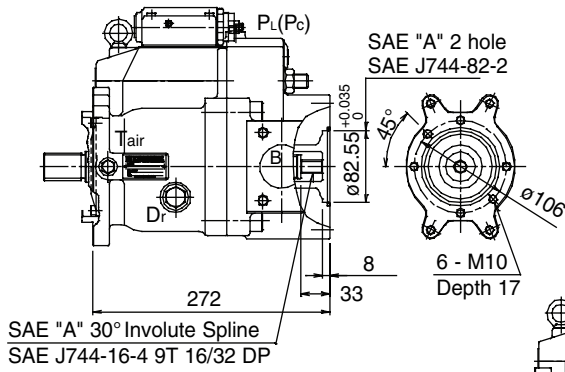

Through Drive "B"

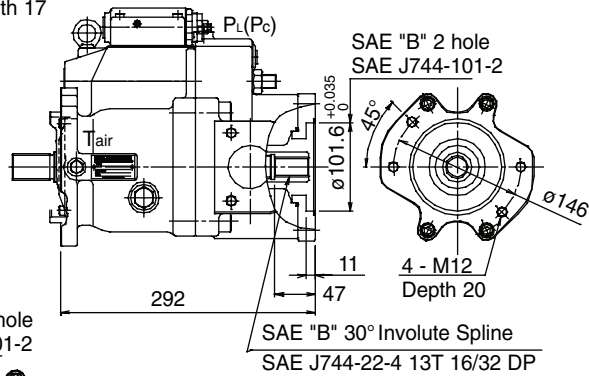

Through Drive "BB"

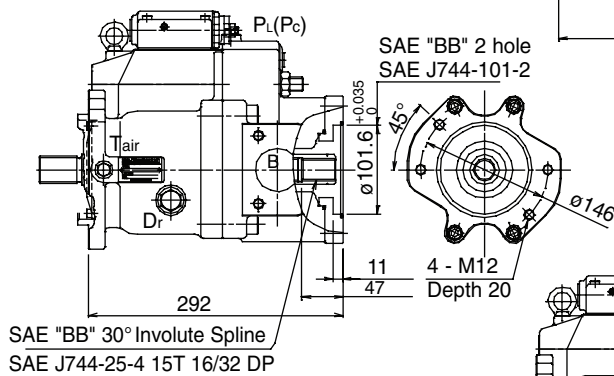

Through Drive "C"

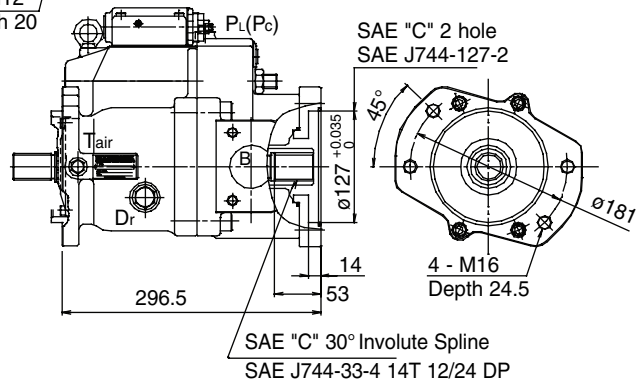

**Unit Dimensions (continued)**

**K3VL80 Adaptor Kits**

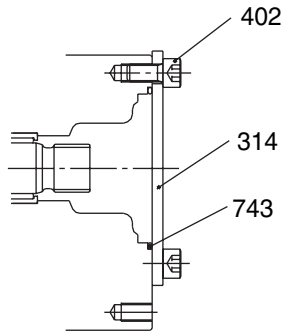

Cover Kit

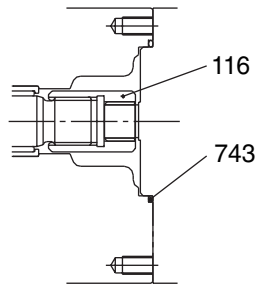

SAE "A"  
T/D Kit

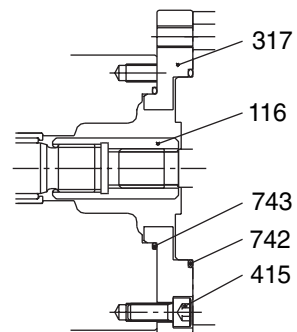

SAE "B", "BB" & "C"  
T/D Kit

No	Part Name	QTY	Cover Kit	SAE "A" T/D Kit	SAE "B" T/D Kit	SAE "BB" T/D Kit	SAE "C" T/D Kit
—	T/D Kit		29L8TN	29L8TA	29L8TB	29L8T2	29L8TC
743	O-Ring	1	00RBG85	00RBG85	00RBG85	00RBG85	00RBG85
742	O-Ring	1	—	—	00RBG105	00RBG105	00RBG130
415	Screw Hex SHC	4	—	—	0SBM1025	0SBM1025	0SBM1030
402	Screw Hex SHC	2	0SBM1020	—	—	—	—
317	Subplate	1	—	—	2924750-0354	2924750-0354	2924750-0355
314	Cover	1	2923150-0316	—	—	—	—
116	Coupling	1	—	2903150-0241	2903150-0262	2903150-0267	2903150-0263



**Unit Dimensions (continued)**

**K3VL112/140 Installation**

K3VL112/140 with Cut-Off / Load Sense Control  
& Torque Limit Module (Clockwise Rotation)

Note  
for counter clockwise rotation,  
the suction port "B" and the  
delivery port "A" are reversed

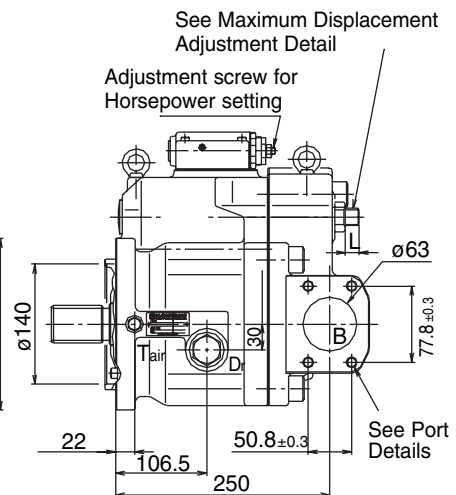
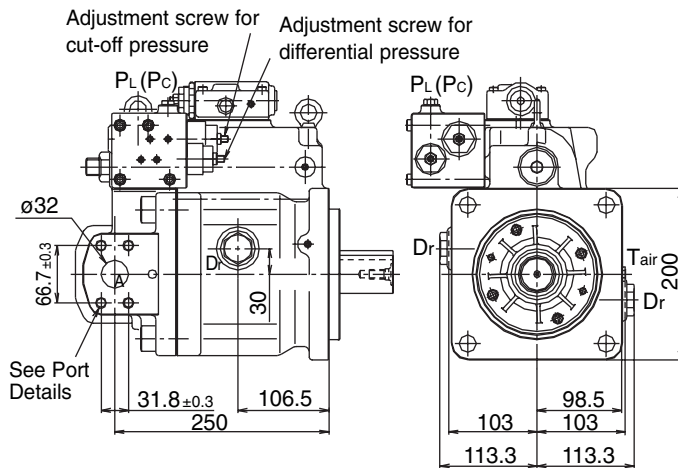
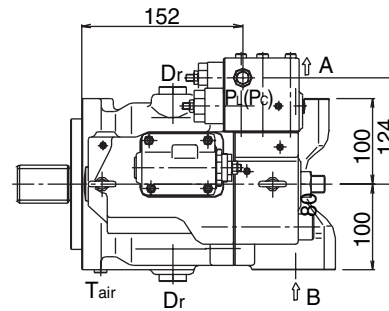
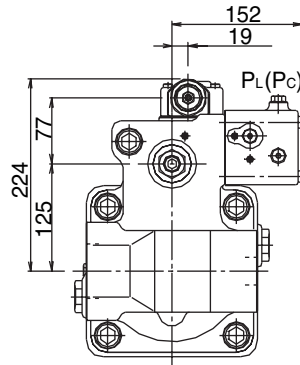

Unit Dimensions (continued)

K3VL112/140 (SAE D 4 BOLT) Mounting Flange & Shaft Options

SAE "D" Type

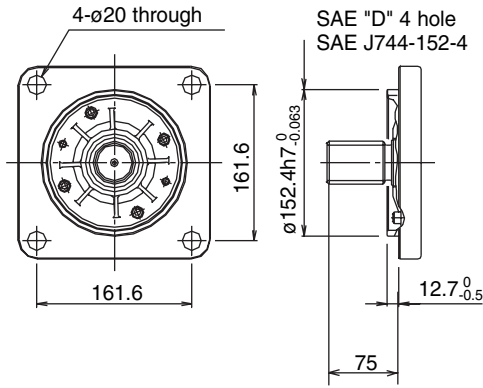

ISO Type

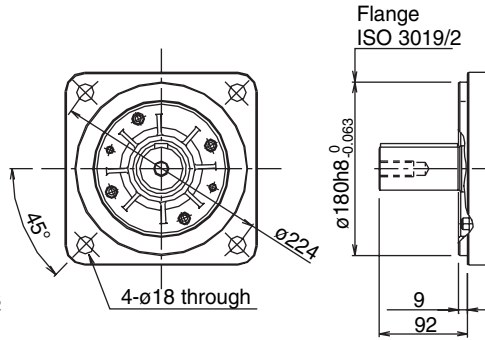

SAE Spline Shaft

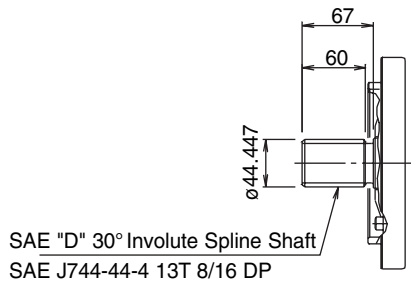

SAE Straight Shaft

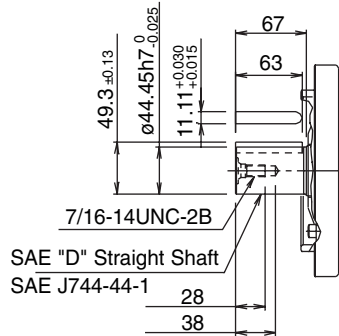

ISO Straight Shaft

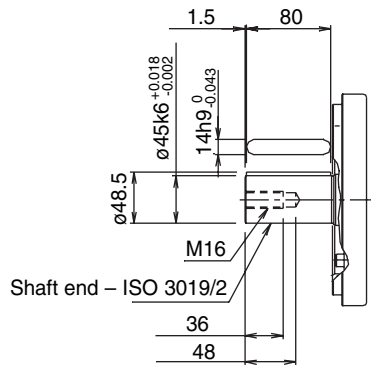

**Unit Dimensions (continued)**

**K3VL112/140 Rear Port Option**

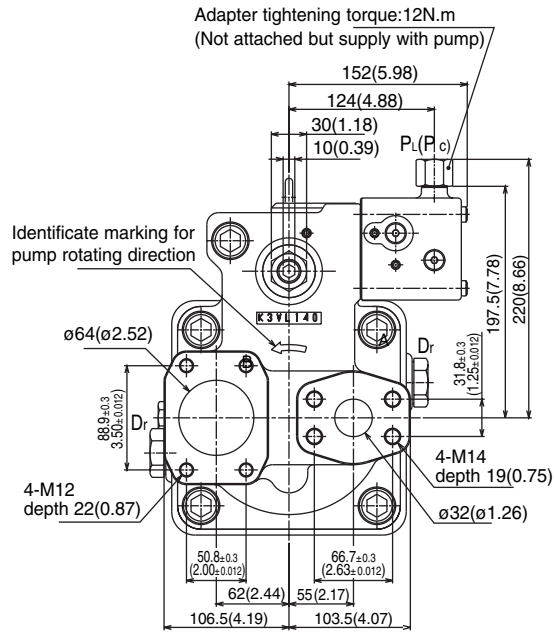
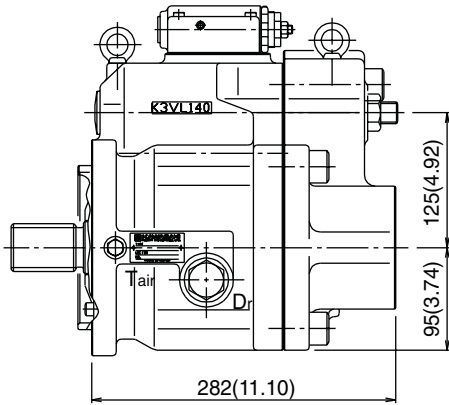

**K3VL112/140 Porting Details**

**Main SAE Flanged Ports**

Des.	Port Name	Port Size	Tightening Torque (Nm)	Flange Threads
------	-----------	-----------	------------------------	----------------

UNF Threaded Version ("S" in position 9 of model code)

A	Delivery Port	SAE J518C high pressure (code 62) 1 1/4"	98	1/2-13UNC-2B x 22mm
B	Suction Port	SAE J518C Std pressure (code 61) 2 1/2"	98	1/2-13UNC-2B x 22mm

Metric Version ("M" in position 9 of model code)

A	Delivery Port	SAE J518C high pressure (code 62) 1 1/4"	157	M14 x 19
B	Suction Port	SAE J518C Std pressure (code 61) 2 1/2"	98	M12 x 17

**Auxiliary Ports**

Des.	Port Name	Port Size	Tightening Torque (Nm)
------	-----------	-----------	------------------------

SAE Version ("S", "K", "C", "R", "U", "X" or "T" in position 8 of model)

Dr	Drain Port (x2)	SAE J1926/1 Straight thread O ring boss 3/4" OD Tube 1 1/16-12UN-2B	167
PL PC	Load Sensing Port Pressure Control Port	SAE J1926/1 Straight thread O ring boss 1/4" OD Tube 7/16-20UNF-2B	12
Tair	Air Bleeder Port	SAE J1926/1 Straight thread O ring boss 1/4" OD Tube 7/16-20UNF-2B	12

ISO Version ("M" in position 8 of model code)

Dr	Drain Port (x2)	M27 x 2 DIN 3852	167
PL PC	Load Sensing Port Pressure Control Port	M14 x 1.5 DIN 3852	25
Tair	Air Bleeder Port	M14 x 1.5 DIN 3852	25



Unit Dimensions (continued)

K3VL112/140 (2 Bolt) Installation

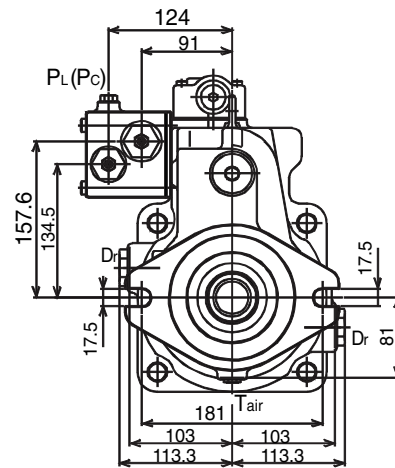
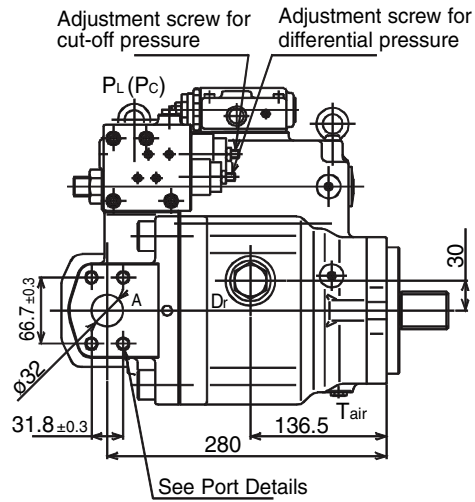
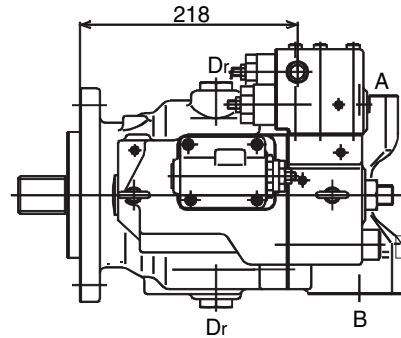
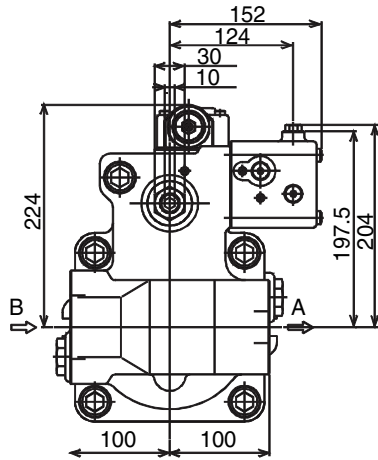

See Port Details

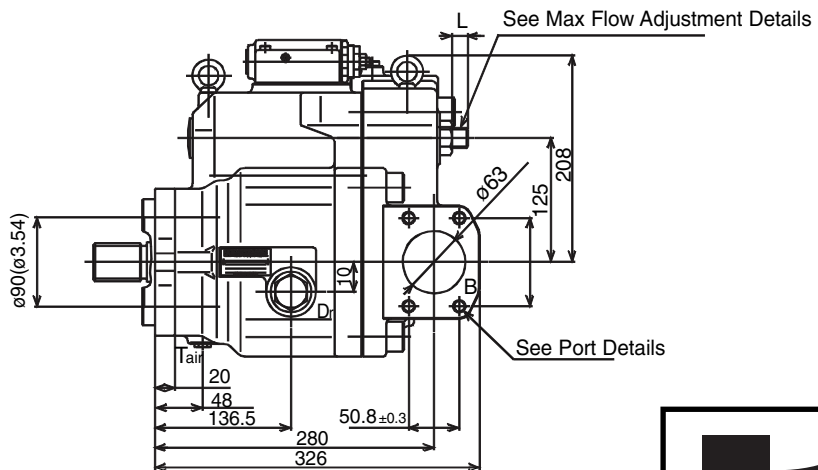

Unit Dimensions (continued)

K3VL112/140 Mounting Flange (2 Bolt) and Shaft Options

SAE "C" Type

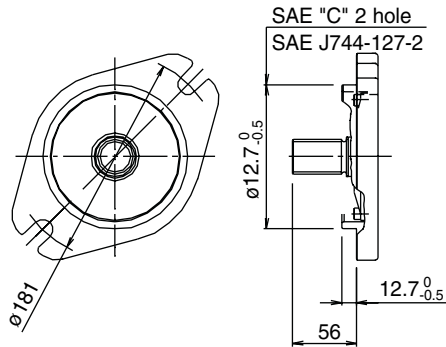

SAE "C" Spline Shaft

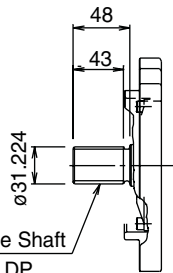

SAE "C" 30° Involute Spline Shaft  
SAE J744-32-4 14T 12/24 DP

SAE "C" Straight Shaft

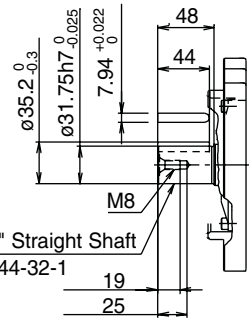

SAE "C" Straight Shaft  
SAE J744-32-1

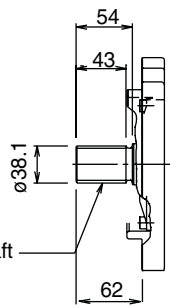

SAE "CC" 30°  
Involute Spline Shaft  
SAE J744-38-4  
17T 12/24 DP

Shaft Detail – SAE "CC" Spline



**Unit Dimensions (continued)**

**K3VL112/140 Through Drive Options**

**Through Drive "A"**

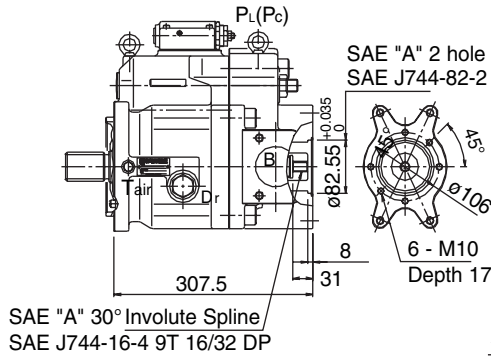

**Through Drive "B"**

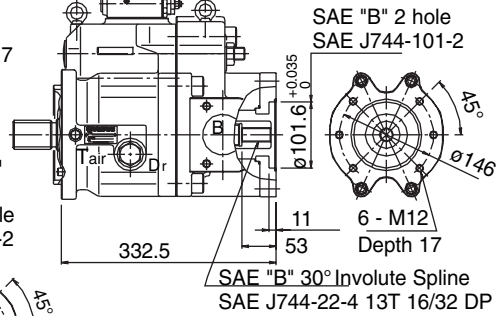

**Through Drive "BB"**

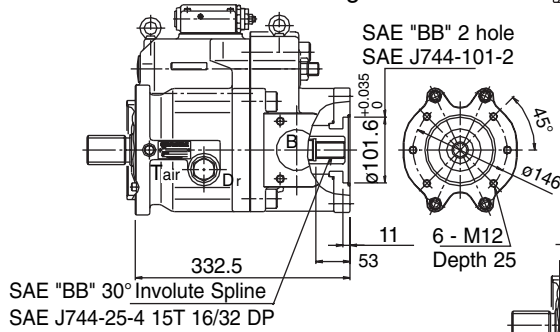

**Through Drive "C"**

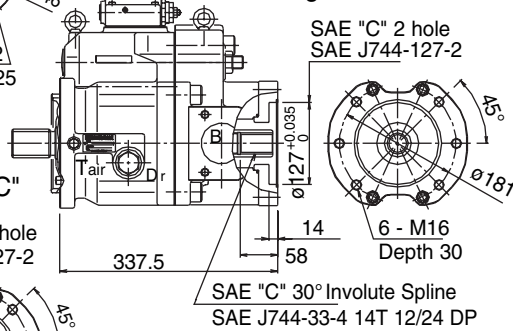

**Through Drive "CC"**

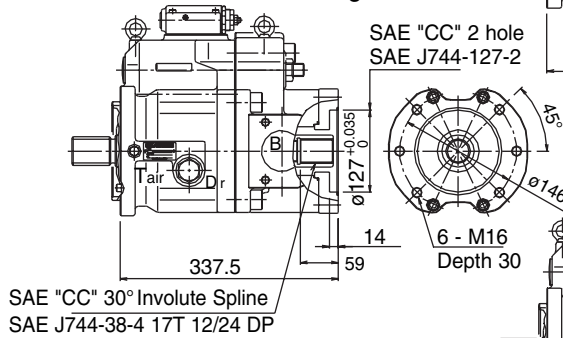

**Through Drive "D"**

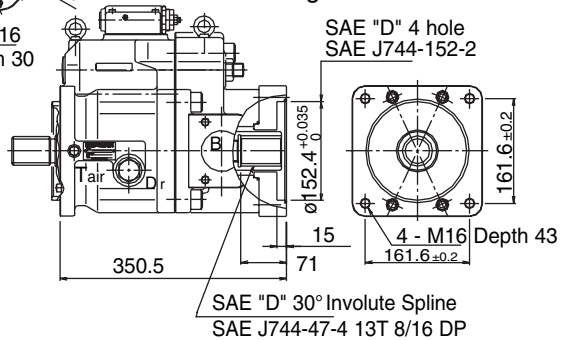

**Unit Dimensions (continued)**

**K3VL112/140 Adaptor Kits**

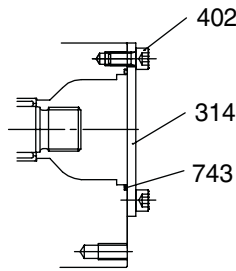

Cover Kit

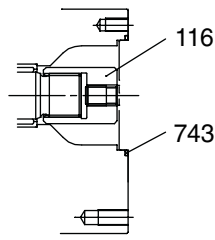

SAE "A" T/D Kit

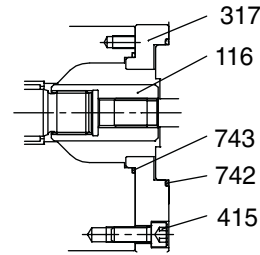

SAE "B" T/D Kit

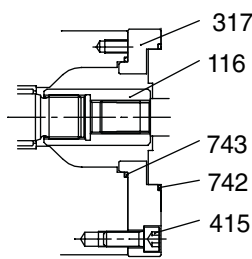

SAE "BB" T/D Kit

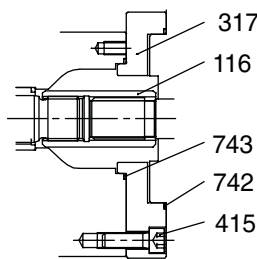

SAE "C" T/D Kit

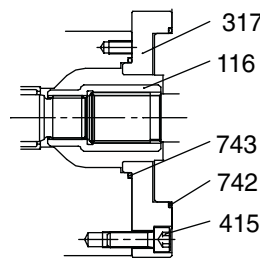

SAE "CC" T/D Kit

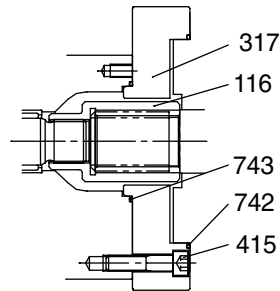

SAE "D" T/D Kit

No	Part Name	QTY	Cover Kit	SAE "A" T/D Kit	SAE "B" T/D Kit	SAE "BB" T/D Kit
—	T/D Kit		29L8TN	29LHTA	29LHTB	29LHT2
743	O-Ring	1	00RBG85	00RBG85	00RBG85	00RBG85
742	O-Ring	1	—	—	00RBG105	00RBG105
415	Screw Hex SHC	4	—	—	0SBM1230	0SBM1230
402	Screw Hex SHC	2	0SBM1020	—	—	—
317	Subplate	1	—	—	2924750-0360	2924750-0360
314	Cover	1	2923150-0316	—	—	—
116	Coupling	1	—	2903150-0268	2903150-0269	2903150-0270

No	Part Name	QTY	SAE "C" T/D Kit	SAE "CC" T/D Kit	SAE "D" T/D Kit
—	T/D Kit		29LHTC	29LHT3	29LHTD
743	O-Ring	1	00RBG85	00RBG85	00RBG85
742	O-Ring	1	00RBG130	00RBG130	00RBG150
415	Screw Hex SHC	4	0SBM1235	0SBM1235	0SBM1250
	Screw Hex SHC	2	—	—	—
317	Subplate	1	2924750-0361	2924750-0361	2924750-0362
314	Cover	1	—	—	—
116	Coupling	1	2903150-0271	2903150-0272	2903150-0273



Unit Dimensions (continued)

K3VL200 Installation

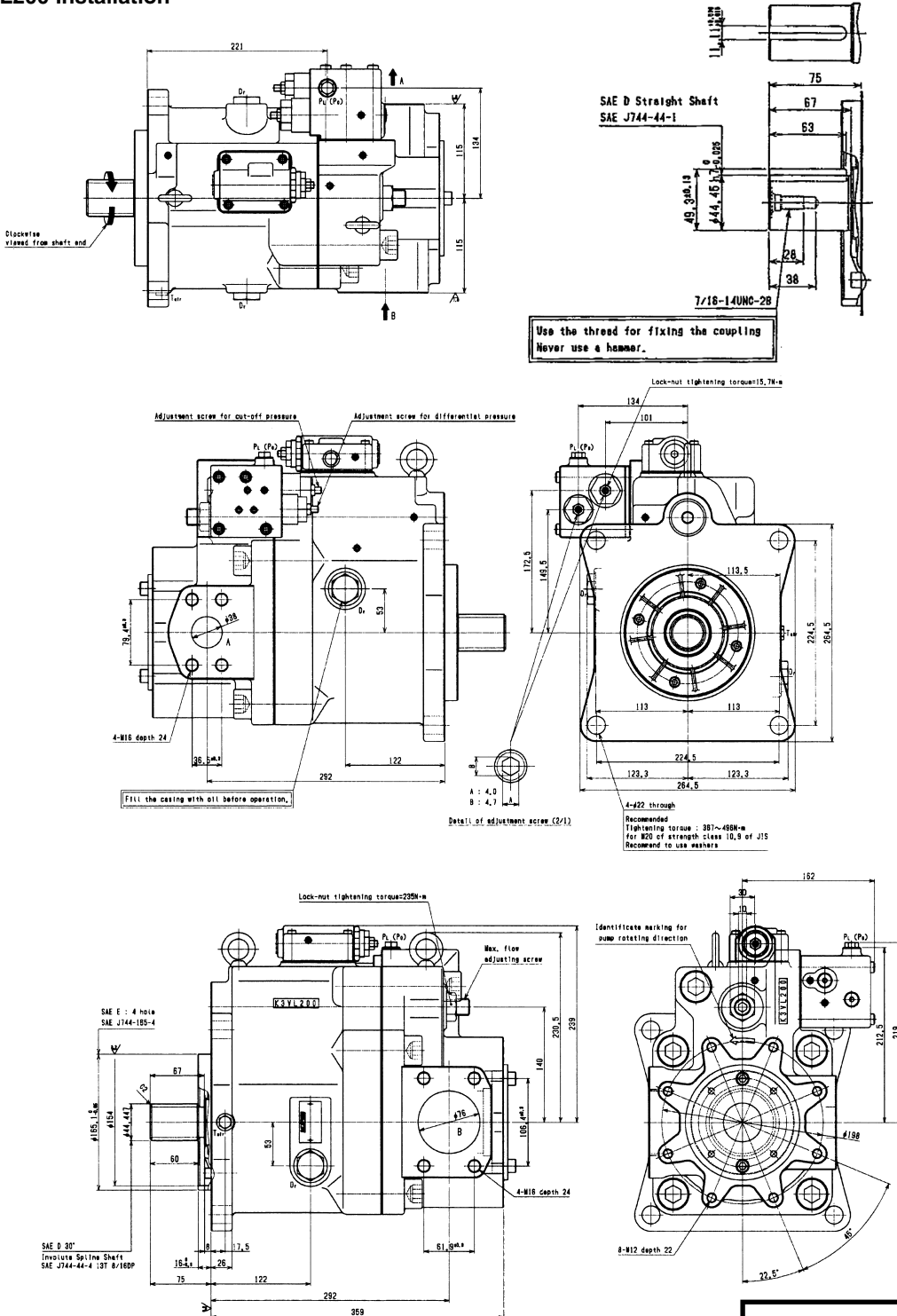

Model  
K3VL

Page  
61.64

Data Sheet  
P-1002/01.06



**Unit Dimensions (continued)**

K3VL200

No	Part Name	QTY	SAE "A"
—	T/D Kit		29LKTA
116	Coupling K3VL 200	1	2903150-0761
317	Sub Plate K3VK 200	1	2924750-0674
407	SHCS	4	0SBM825
712	O-Ring 84.4 I/D x 3.1 Sec	1	00RBG85
742	O-Ring 84.4 I/D x 3.1 Sec	1	00RBG85

No	Part Name	QTY	SAE "B"	SAE "C"	SAE "D"	SAE "E"
—	T/D Kit		29LKTB	29LKTC	LKTD	29LKTE
116	Coupling K3VL 200	1	2903150-0762	2903150-0763	2903150-0764	2903150-0764
317	Sub Plate K3VK 200	1	2924750-0675	2924750-0667	2924750-0677	2924750-0686
407	SHCS	8	0SBM1230	0SBM1230	0SBM1245	0SBM1245
712	O-Ring	1	00RBG120	00RBG125	00RBG125	00RBG125
742	O-Ring	1	00RBG105	00RBG130	PCPP155	PCPP170

**K3VL200 Porting Details**

Des.	Port Name	Port Size	Tightening Torque (Nm)	Flange Threads
------	-----------	-----------	------------------------	----------------

UNC Threaded Version ("S", "K" in position 9 of model code)

A	Delivery Port	SAE J518C high pressure (code 62) 1 1/2"	235	5/8-11UNC-2B
B	Suction Port	SAE J518C Std pressure (code 61) 3"	235	5/8-11UNC-2B

Metric Version ("M" in position 9 of model code)

A	Delivery Port	SAE J518C high pressure (code 62) 1 1/2"	235	M16
B	Suction Port	SAE J518C Std pressure (code 61) 3"	235	M16

**Auxiliary Ports**

Des.	Port Name	Port Size	Tightening Torque (Nm)
------	-----------	-----------	------------------------

SAE Version ("S", "K" in position 8 of model)

Dr	Drain Port (x2)	SAE J1926 Straight thread O ring boss 3/4" O.D Tube 1.1/16-12UNF-2B	167
PL PC	Load Sensing Port Pressure Control Port	SAE J1926 Straight thread O ring boss 1/4" O.D Tube 7/16-20UNF-2B	12
Tair	Air Bleed Port	SAE J1926 Straight thread O ring boss 1/4" O.D Tube 7/16-20UNF-2B	12

Model  
K3VLPage  
62.64Data Sheet  
P-1002/01.06

**Unit Dimensions (continued)**

Electrical Displacement Control

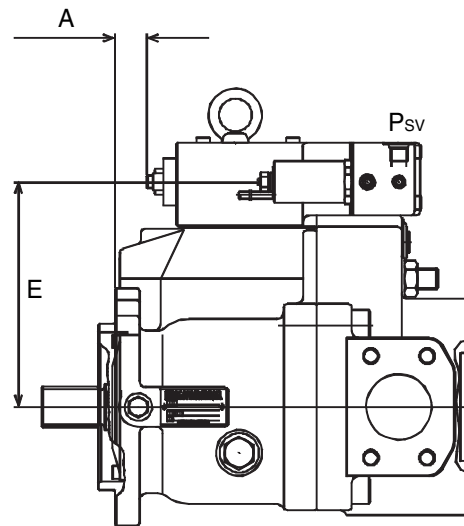
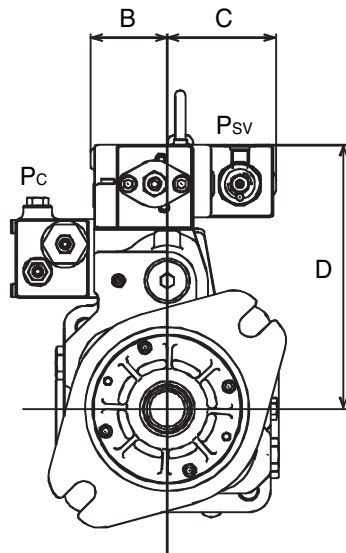
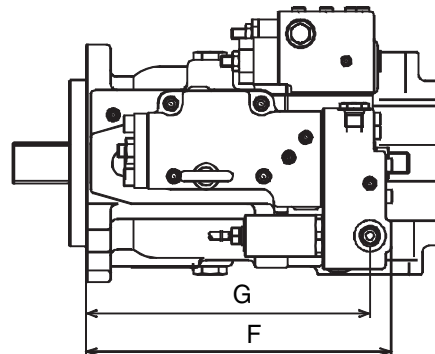

Installation Dimensions (mm)

Pump Size	A	B	C	D	E	F	G
K3VL45	21	52	90	187	157	226	210
K3VL80	25	59	83	202	172	233	217
K3VL112/140	38	64	78	244	214	247	231

**Unit Dimensions (continued)**

Unloading valve module (\*N)

	<b>A</b>	<b>B</b>
K3VL45	169	155
K3VL80	169	166
K3VL112/140	202	190
K3VL200	212	205

Proportional pressure module (\*V)

	<b>A</b>	<b>B</b>
K3VL45	179	233
K3VL80	179	244
K3VL112/140	212	280
K3VL200	222	295

A: Distance between the centre line of the pump and the top of the bolt head for the cut off regulator.  
 B: Distance between the centre line of the pump and top of the solenoid valve.

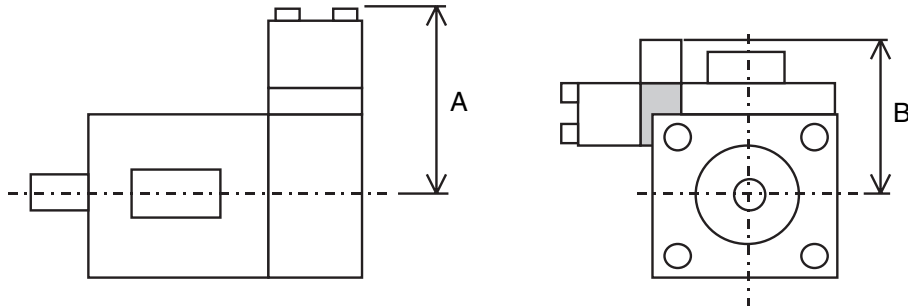

KAWASAKI PRECISION MACHINERY (UK) LTD  
 Ernesettle, Plymouth, Devon, PL5 2SA, England  
 Tel: +44 1752 364394 Fax: +44 1752 364816  
 E Mail: info@kpm-uk.co.uk  
 Web site: <http://www.kpm-eu.com>

The specified data is for product description purposes only and may not be deemed to be guaranteed unless expressly confirmed in the contract

ALL RIGHTS RESERVED, SUBJECT TO REVISION

Model  
K3VL

Page  
64.64

Data Sheet  
P-1002/01.06

